

ISO QUICK ATTACH MATERIAL BUCKETS

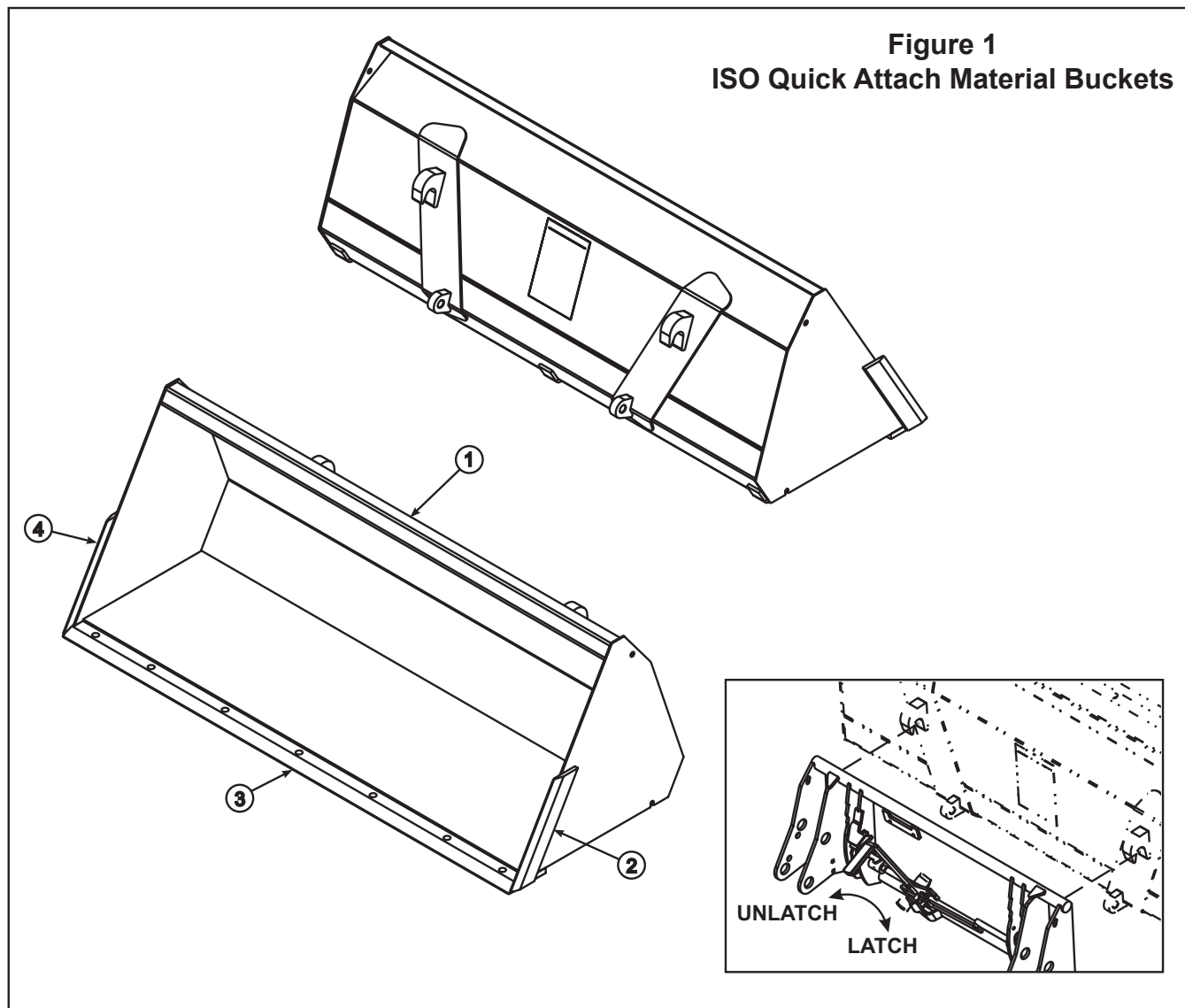

PARTS LIST - BUCKET KIT

Item	Part No.	Description	Qty.
1	*	BUCKET, 72" Heavy Duty ISO Quick Attach (Includes cutting edges)	1
	*	BUCKET, 84" Heavy Duty ISO Quick Attach (Includes cutting edges)	1
	*	BUCKET, 96" Heavy Duty ISO Quick Attach (Includes cutting edges)	1
	*	BUCKET, 108" Heavy Duty ISO Quick Attach (Includes cutting edges)	1
2	28086-1	CUTTING EDGE, Left Side (H.D.)	1
3	46734-1	CUTTING EDGE, Bottom (72" Heavy Duty, with holes)	1
	46734-2	CUTTING EDGE, Bottom (84" Heavy Duty, with holes)	1
	46734-4	CUTTING EDGE, Bottom (96" Heavy Duty, with holes)	1
	50868-1	CUTTING EDGE, Bottom (108" Heavy Duty, with holes)	1
4	28086-2	CUTTING EDGE, Right Side (H.D.)	1

* Not sold as repair part.

2-7752
 2-7753
 2-7764
 2-7765

ATTACHING QUICK ATTACH MATERIAL BUCKET

No tools are needed to install quick attach material buckets. Loader must be equipped with ISO quick attach device.



WARNING: To avoid injury during attachment or detachment, do not allow bystanders within 10 feet of loader or attachment.

1. Locate tractor and attachment on level ground. Lower boom to rest on the ground. Extend the bucket cylinders slightly, while raising the boom to provide three to five inches of ground clearance, drive the tractor ahead slowly toward the attachment, aligning the loader quick attach device.
2. While driving the tractor ahead slowly to maintain contact with the attachment, activate the lift cylinders to raise the loader until the quick attach engages under the attachment lip.
3. Then activate bucket cylinders to retract, continuing to roll the attachment back completely.
4. Place tractor in neutral, set parking brake, and shut off tractor. Move latch pin handles to latch (down) position.
5. Start tractor. and activate lift cylinders to raise attachment one or two feet off the ground and extend bucket cylinders to tilt attachment at a slight downward angle, so quick attachment latch pins are visible. Visually inspect the attachment mechanism to verify that the pins are engaged through the latch plate on the back of the attachment.

NOTE: If the attachment is not securely attached, follow the instructions for detaching it and repeat the above procedure.

DETACHING QUICK ATTACH MATERIAL BUCKET



WARNING: To avoid injury during installation of the loader attachment, do not allow bystanders within 10 feet of loader or attachment.

1. Locate tractor and loader on level ground.
2. Lower boom arms until the attachment is level and resting on ground.
3. Place tractor in neutral, set parking brake, shut off tractor engine and disengage quick attach device latch pins by moving handles to unlatch position.
4. Start tractor engine, release brake and extend bucket cylinders while slowly backing the tractor away from attachment, until quick attach disengages from attachment.

BUCKET MODEL	BUCKET WIDTH		STRUCK CAPACITY	
	Inches	Centimeters	Cubic Yards	Cubic Meters
72" H.D.	72	183	0.55	0.42
84" H.D.	84	213	0.63	0.48
96" H.D.	96	244	0.76	0.58
108" H.D.	108	274	1.34	1.02

INSTALLATION INSTRUCTIONS