

Keep With Operator's Manual

GRILLE GUARD KUBOTA TRACTORS

TRACTOR MODELS

M-110 & M-120

TRACTOR AND GRILLE GUARD GENERAL INFORMATION

Grille guard can be installed on tractor using tools ordinarily available, including metric wrenches and a torque wrench.

Grille guard can be used on tractors with or without front weights.

Grille guard is designed to be compatible with 5211 loader. If loader is to be installed, install grille guard while installing loader mid mounting brackets. Attachment plates of loader mid mounting brackets replace grille guard spacer plates. Refer to instructions at right and instructions provided with loader mounting kit.

Shut off engine and engage brakes during installation.

INSTALLING GRILLE GUARD (Figure 1)

NOTE: Install all attaching hardware loosely (unless noted otherwise) until grille guard is completely assembled to facilitate assembly and proper alignment.

NOTE: If tractor is to be equipped with loader, do not use spacer plates (8 & 9). Place grille guard attachment plates over attachment plates of mid mounting brackets. Replace shorter 18mm cap screws and flat washers provided with loader mounting kit, with 18mm x 80mm cap screws (10) and lock washers (11) to fasten grille guard (1) and loader mid mounting brackets to tractor front frame casting.

1. Support grille guard (1) and spacer plates (8 & 9) at front of tractor and fasten grille guard (1) to sides of tractor front frame casting using 18mm x 80mm cap screws (10) and 18mm lock washers (11).
2. Torque all 18mm-1.5 x 80mm cap screws (10) to 192 ft.-lbs. (260 N-m) of torque.

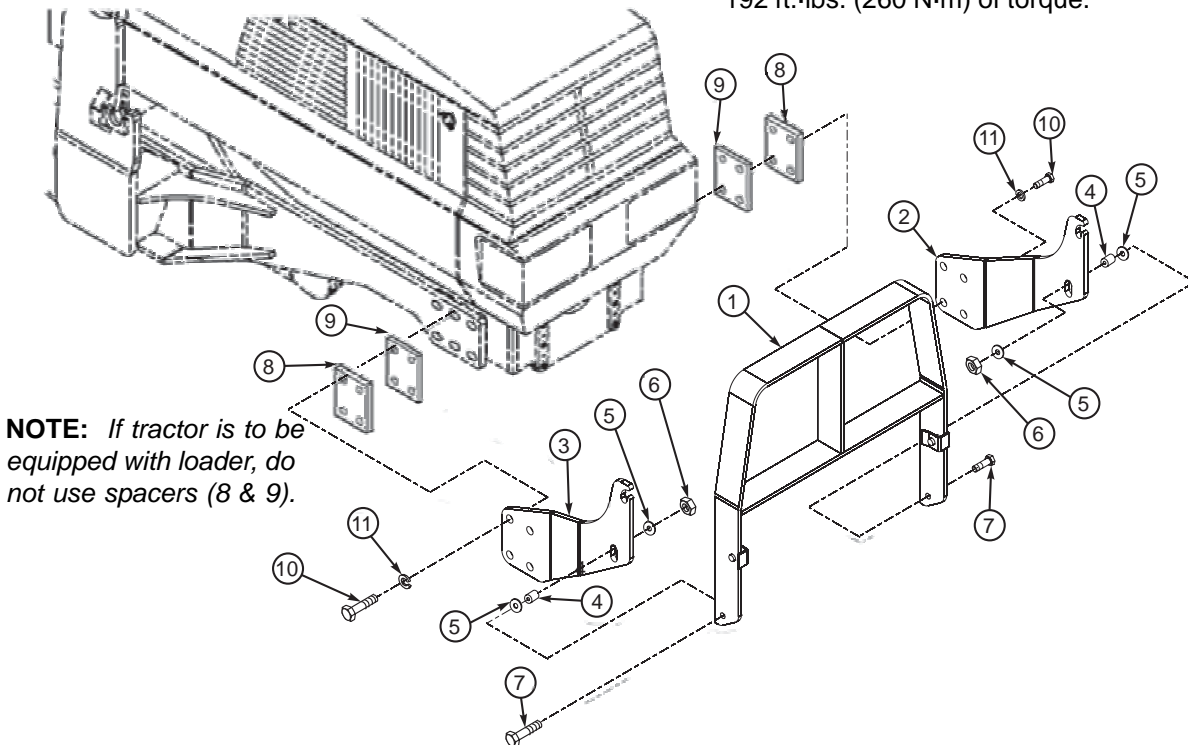
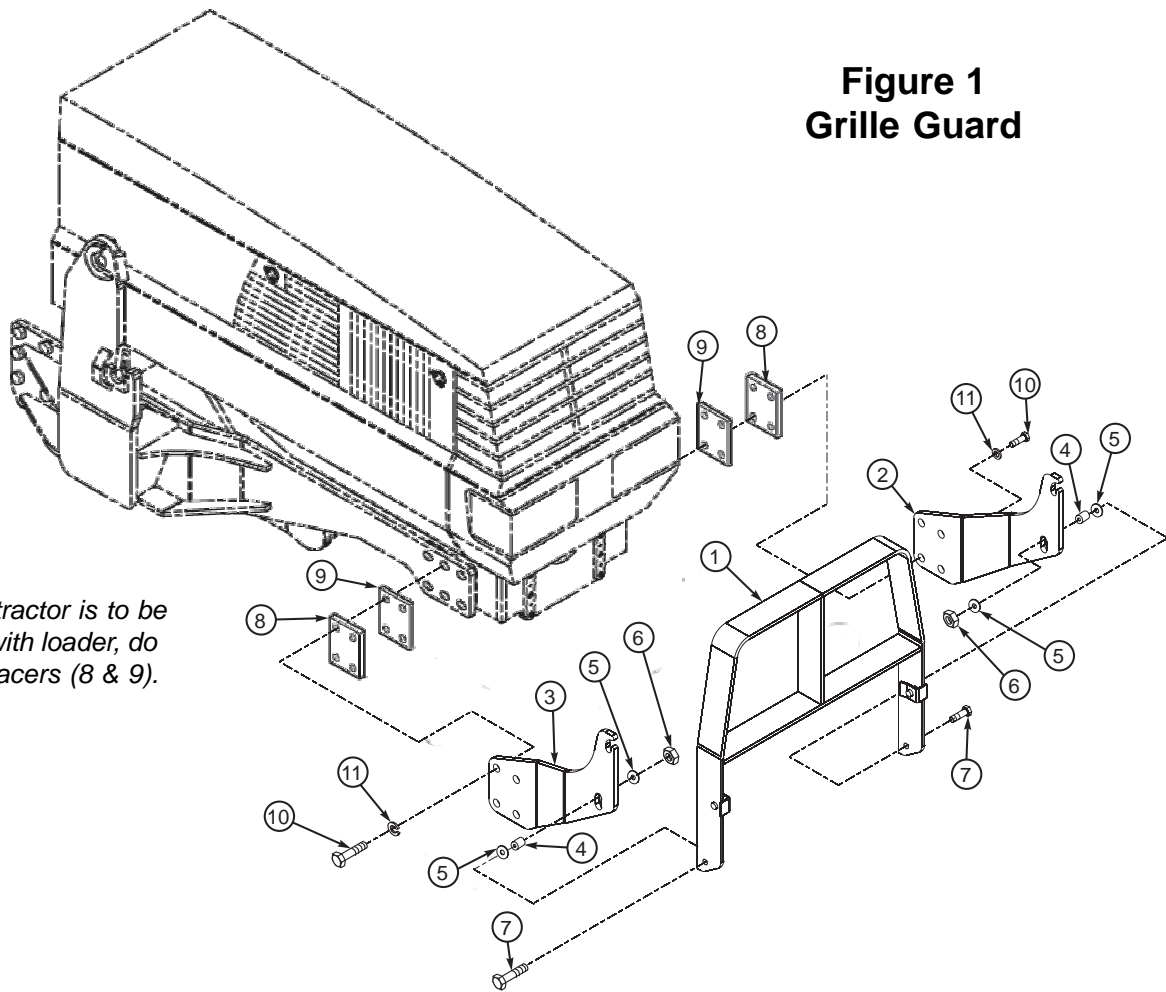

Figure 1
Grille Guard

NOTE: If tractor is to be equipped with loader, do not use spacers (8 & 9).



NOTE: If tractor is to be equipped with loader, place attachment plates of grille guard (1) over attachment plates of loader mid mounting brackets. Replace shorter 18mm cap screws and flat washers provided with loader mounting kit, with 18mm x 80mm cap screws (10) and lock washers (11) to fasten grille guard (1) and loader mid mounting brackets to tractor front frame casting.

PARTS LIST – GRILLE GUARD

Item	Part No.	Description	Qty.
1	53372	GRILLE GUARD	1
2	53373-1	SIDE PLATE, Left	1
3	53373-2	SIDE PLATE, Right	1
4	47427-1	SPACER TUBE	2
5	2502-30	WASHER, Flat, 1/2"	4
6	41840-5	NUT, Lock, 1/2"	2
7	41838-12	SCREW, Cap, 1/2" x 1-3/4"	2
8	50622	PLATE, Spacer, 3/4" Thick	2
9	50615	PLATE, Spacer, 1/2" Thick	2
10	42672-63	SCREW, Cap, 18mm-1.50 x 80mm, Class 8.8	8
11	48093-1	WASHER, Lock, 18mm	8

INSTALLATION INSTRUCTIONS