

<i>Keep With Operator's Manual</i>

LOADER MOUNTING KIT 5211 LOADER KUBOTA TRACTORS

MODEL	2WD	FWA	ROPS	CAB
M-110	X	X		X
M-120	X	X		X

TRACTOR & LOADER GENERAL INFORMATION

Mounting kit can be installed using tools ordinarily available, including a hoist capable of lifting and supporting the loader for initial mounting, standard wrenches, torque wrench, hydraulic oil, and a non-sparking drift and hammer (a shot-filled mallet is recommended).

Tractor-supplied hydraulic power is required for loader mounting and operation. A hydraulic kit option is available for use with this loader:

A is a hose kit for use with existing tractor hydraulic control valves, which includes hoses and couplings to plumb to tractor rear remote valve couplers.

If optional grille guard is to be installed, install it during mid mounting bracket installation, before mounting loader. Refer to instructions provided with grille guard.

Check tractor tire pressure. Refer to tractor operator's manual for recommended pressures. With tractor on a firm, level surface, compare tractor rear axle height from left to right, measuring from axle center to ground. Adjust air pressure in rear tires until axle height measures same for both sides.

NOTE: *If rear axle on tractor is not level from side to side, cutting edge on loader bucket or similar loader-mounted attachments will not sit flat on ground.*

When loader mounting is complete, you will need to check front tire clearances and adjust tire track width as necessary.

You will also need to verify tractor wheel and axle clearances and adjust steering stops accordingly to provide clearance between front tire and tractor hood and loader on full left and right turn with front axle fully oscillated. Be sure lift cylinders are fully retracted when checking tire clearances. Refer to tractor operator's manual for steering stop adjustment.

Tractor steering stops may have to be adjusted to provide clearance between front tire and loader on full left and right turn with front axle fully oscillated. Be sure lift cylinders are fully retracted when checking tire clearances. Refer to tractor operator's manual for steering stop adjustment.

If tractor is equipped with front weights, they must be removed. The weight bracket can remain.

Reference to left and right used in these instructions refer to position when seated in the operating position on tractor.

PREPARING TRACTOR

Shut off engine, engage brakes, and remove key during installation. If tractor is equipped with front weights, remove weights. It is not necessary to remove weight bracket.

1. Remove toolbox. Refasten hood frame flange and cab bracket using HHCS 1/2 x 1" (14) and 1/2" hex locknut (11).
2. Using existing hardware and 7/16 washers (14) as spacers, refasten hose hanger to engine mount.
3. Remove (2) 18 mm bolts per side from cab flange fastened to transmission boss.

Remove plastic thread protectors from holes on left and right sides of tractor.

IMPORTANT: Clean threaded holes in tractor chassis thoroughly using a tap of proper size. Paint, rust, or debris in the threads may not permit cap screws to be installed and tightened correctly.

INSTALLING LEFT & RIGHT MIDMOUNTING BRACKETS (FIGURE 1)

NOTE: *Install all attaching hardware loose until mounting kit is completely assembled, to facilitate assembly and proper alignment-unless noted otherwise. Torque all hardware to torques specified in General Torque Specifications table when assembly is complete.*

NOTE: *Support mid mounting brackets (1 & 2) when removing from shipping materials.*

1. Using a hoist, lift left mid mounting (4) and align with front tractor frame holes. Using one 18 mm x 65 mm bolt (8), one 18 mm lock washer (15) and one 3/4" flat washer (13), attach front of mid mount at top slot; third from the end. Rotate mid mounting until rear holes align with holes in tractor transmission casting. Attach using 18 mm x 60 mm bolts (7) and 18 mm lock washers (15). Slide spacer plate (5) between front of mid mounting and tractor frame. Finish attaching using 18 mm x 65 mm bolts (8), 18 mm lock washers (15), and 3/4" flat washers (13).
2. Using a hoist, lift right mid mounting (4) and align with front tractor frame holes. Using one 18 mm x 65 mm bolt (8), one 18 mm lock washer (15) and one 3/4" flat washer (13), attach front of mid mount at top slot; third from the end. Rotate mid mounting until rear holes align with holes in tractor transmission casting (Take care not to damage fuel filter when rotating mid mounting). Attach using 18 mm x 60 mm bolts (7) and 18 mm lock washers (15). Slide spacer plate (5) between front of mid mounting and tractor frame. Finish attaching using 18 mm x 65 mm bolts (8), 18 mm lock washers (15), and 3/4" flat washers (13).
3. Install rear crosstie assembly (1) to underside of tractor transmission casting using 18 mm x 75 mm (9) bolts and 18 mm lock washers (15). Attach to left and right mid mounting (3 & 4) using 5/8 x 2" bolts (10) and 5/8" hex lock nuts (16).
4. Install front cross tie (2) to left and right mid mounting (3 & 4) using 5/8 x 2" bolts (10) and 5/8" hex lock nuts (16).
5. Tighten all bolts to recommended torque specifications found in torque table.

18 mm	172 ft lbs (233 N.m)
1/2"	65 ft lbs (88 N.m)
5/8"	126 ft lbs (171 N.m)

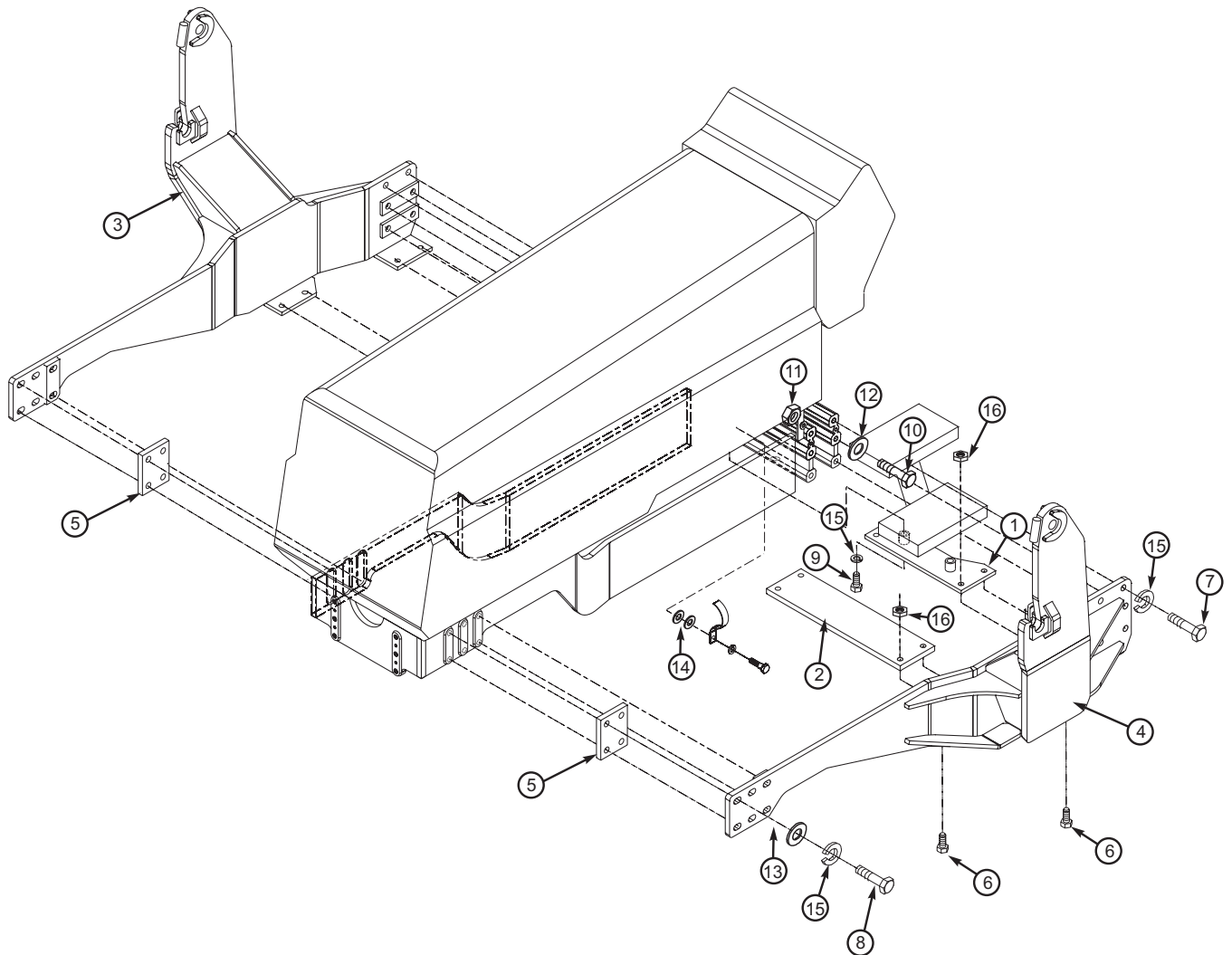

PARTS LIST - MOUNTING KIT

Item	Part Number	Description	Qty.
1	50617	CROSSTIE ASSEMBLY, REAR	1
2	50616	CROSSTIE/ FRONT	1
3	50623-1	MID MOUNTING ASSEMBLY, LEFT	1
4	50623-2	MID MOUNTING ASSEMBLY, RIGHT	1
5	50615	SPACER PLATE	2
6	41838-27	HHCS 5/8 X 2"	8
7	42672-20	HHCS 18MM - 1.50 X 60MM	12
8	42672-61	HHCS 18MM - 1.50 X 65MM	12
9	42672-62	HHCS 18MM - 1.50 X 75MM	2
10	41838-47	HHCS 1/2 X 1"	1
11	41840-5	NUT/HEX LOCK 1/2"	1
12	42502-10	WASHER/ FLAT 1/2"	1
13	42502-13	WASHER/ FLAT 3/4"	12
14	42502-9	WASHER/ FLAT 7/16"	2
15	48093-1	WASHER/ LOCK 18MM	26
16	41840-7	NUT/HEX LOCK 5/8"	8

MOUNTING LOADER TO TRACTOR (Figures 1, 3, 4, 5, 6, 7 & 8)

WARNING: Loader must be supported before removing hardware securing loader to shipping pallet, or loader will tip over.



WARNING: To avoid injury during installation of quick attach loader, do not permit bystanders within ten feet of loader.

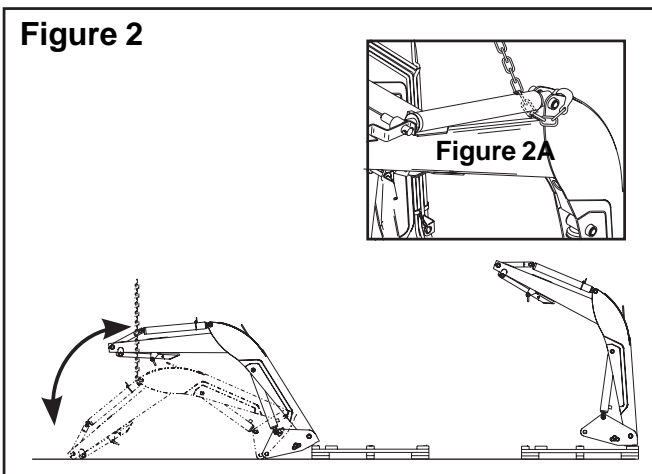

WARNING: To avoid injury during installation of quick attach loader, an overhead hoist must be used for initial mounting. Parking stands are not operational without bucket or heavy attachment mounted. Bale spear or pallet fork alone do not provide enough weight.

Figure 2

1. Loop chain or sling under each bucket cylinder and hook on loader boom arm (see figure 2A). Using overhead hoist to support loader, remove shipping angle braces (C) (figure 3) by temporarily removing linch pins (A) to remove angle braces, then reinstall linch pins which hold parking stands in position.
2. Remove nut and washers (B) from shipping braces (C) and discard braces and hardware.
3. Cut tie straps, remove linch pins (H) and hitch pins (I) (see figure 3) and keep with loader for securing uprights to mid-mounting brackets later.
4. Remove hardware (J) from shipping bracket (N). Discard brackets and hardware. Remove nuts and washers (P) from bolts securing loader to pallet. Raise loader.



WARNING: Loader uprights may rotate downward when loader is lifted from pallet.

5. Remove all six carriage bolts (Q) from pallet (see figure 3) and position pallet at rear of loader to facilitate lowering (see figure 2). Lower loader from vertical shipping position to horizontal position (scraps of cardboard may be used to protect paint). Remove bucket level indicator rod (L) attached to oil lines for shipment.

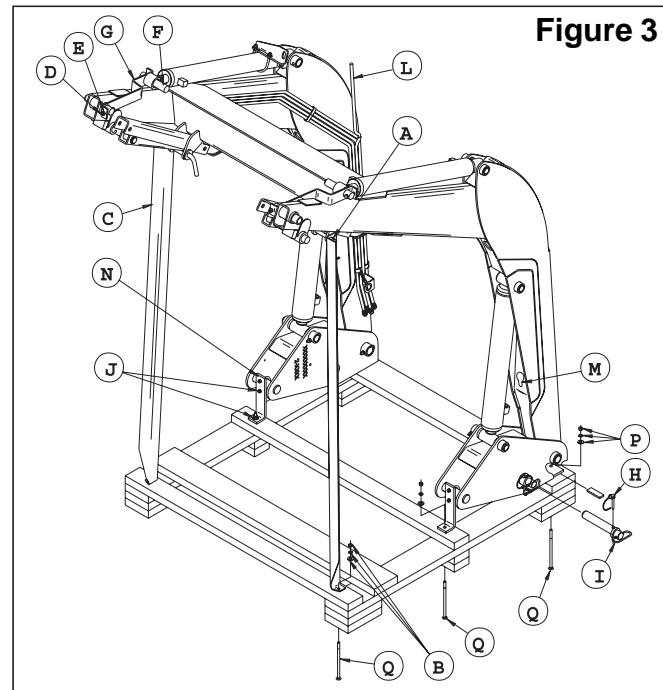
**Figure 3**

6. Install hydraulic plumbing for loader to tractor using either hose or valve kit designed for use with this loader. (Refer to the first page of these instructions for compatible kits.) Follow instruction sheets provided with hose or valve kit to install valve to tractor, if applicable, and install hoses, hose sleeves, quick couplers, dust caps, and identification bands to loader boom oil lines.
7. Secure a hoist strap around the boom arm assembly or secure with a chain hook into hole (M) on underside of boom arm (see figure 3). If using a strap, the strap should be located around the boom arm near the same location as the chain hook hole, similar to figure 4. Slowly raise loader with overhead hoist until loader upright will clear front tractor tires (see figure 4).
8. Drive tractor into loader until uprights of loader mounting brackets are within 12" to 18" of loader uprights. Shut off engine. Set parking brake and remove key. Attach lift cylinder function hoses (color coded green and yellow) to corresponding tractor quick couplers.

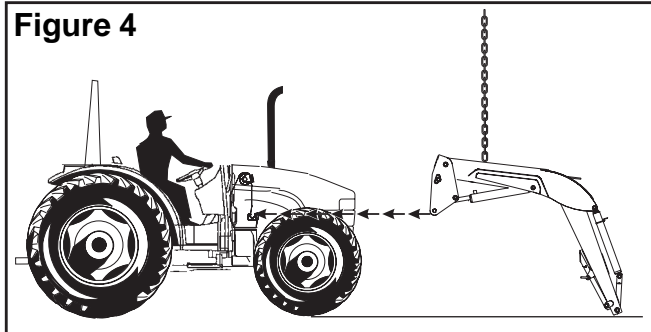

NOTE: It is important to attach lift cylinder hoses (yellow and green spiral band coded) for loader to function properly. Do not connect boom oil line hoses for tilt cylinder control at this time. (Connect these after shipping brackets are removed from attachment pin hubs instruction 12)

9. Start engine. Retract lift cylinders fully and continue to activate control lever for approximately 10 seconds. Cycle cylinders several times to remove air. Extend lift cylinders 10" to 12" from the fully closed position to ensure loader upright pin will be first part of loader upright to make contact with mount vertical stop surface. Shut off engine. Set parking brake and remove key.
10. With overhead hoist, position loader upright pin to clear mount pin saddle by 1" (see figure 5). Move tractor forward until both loader upright pins come to rest against the flat vertical stop surface of both mounts. Lower loader with overhead hoist until both loader upright pins rest into mount pin saddles.

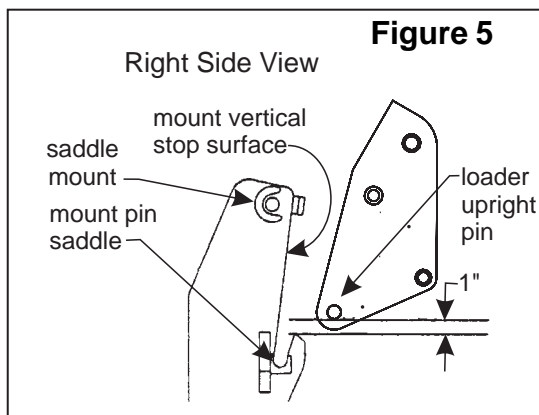

11. Remove hoist chain or strap from loader boom and secure to each bucket cylinder shipping brackets (G) (see figure 3). Using overhead hoist raise front of loader to rotate loader upright into upper mount saddle (see figure 6). Continue to rotate loader upright until upright has fully seated into back of mount saddle. Insert two 1-1/4" x 7" pins (I) and lynch pins (H) which were removed from loader uprights in step 3 (see figure 7). Remove hoist chain or strap from shipping brackets.

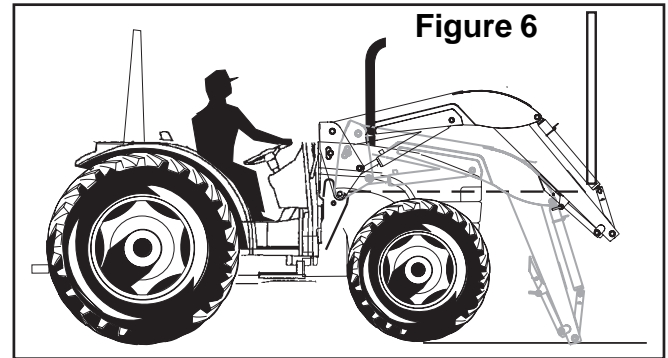

NOTE: In some cases a small amount of additional force may be required to insert the pins. If necessary, use a drift and hammer made of non-sparking material (a shot-filled mallet is recommended) to seat loader uprights into mount saddle.

12. Remove 3/8" cap screws (D), lock nuts (E), pins (F) and shipping brackets (G) (see figure 3). Discard shipping brackets, retain hardware for further use when installing bucket or attachment.

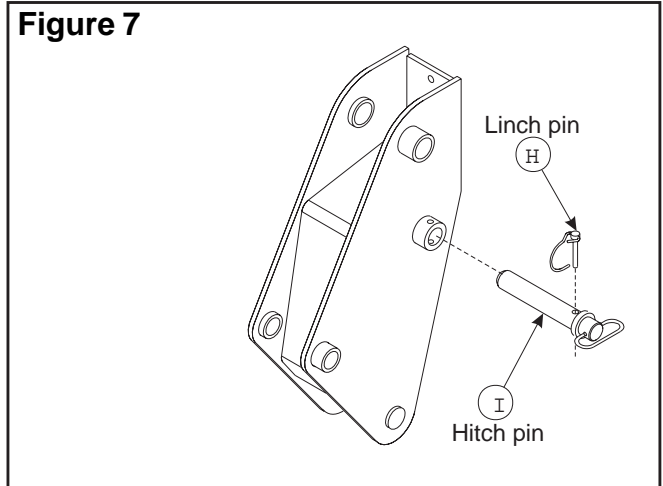

13. Attach tilt cylinder function hoses (color coded blue and red) to corresponding tractor quick couplers.
14. Start engine and fully extend and retract cylinders several times to purge air from hydraulic system. Replenish hydraulic system using tractor operators manual specified hydraulic oil.
15. Adjust front wheel tread settings or steering stops, if necessary, to provide a minimum 3/4" inch clearance between front tires and any part of loader with lift cylinders fully retracted and front axle fully oscillated. Be sure lift cylinders are fully retracted. Refer to page 1 under preparing tractor. Refer to tractor operator's manual for tread setting and steering stop adjustment procedures.

INSTALLING BUCKET OR ATTACHMENT

Refer to loader operator's manual to install bucket or optional attachments.



WARNING: Always have a bucket attachment mounted to loader when it is removed from tractor. Pallet fork, bale spear or similar attachments are too light to safely counterbalance loader boom arms when loader is dismantled from tractor.

ATTACH LEVEL INDICATOR FOR BUCKET OR ATTACHMENT (Figure 8)

Refer to assembly instructions provided with bucket or optional attachments to attach level indicator rod.

NOTE: Attachment level setting varies for each loader attachment. It is important to make sure level indicator is adjusted to indicate level whenever a different attachment is mounted, or else level indicator will not indicate true level.

To adjust level indicator properly, locate tractor and loader attachment on a firm level surface with attachment resting on level surface in operating position. Loosen U-bolt that fastens level indicator bracket to right tilt cylinder and position it so it is centered on the offset in level indicator rod, then retighten U-bolt hardware.

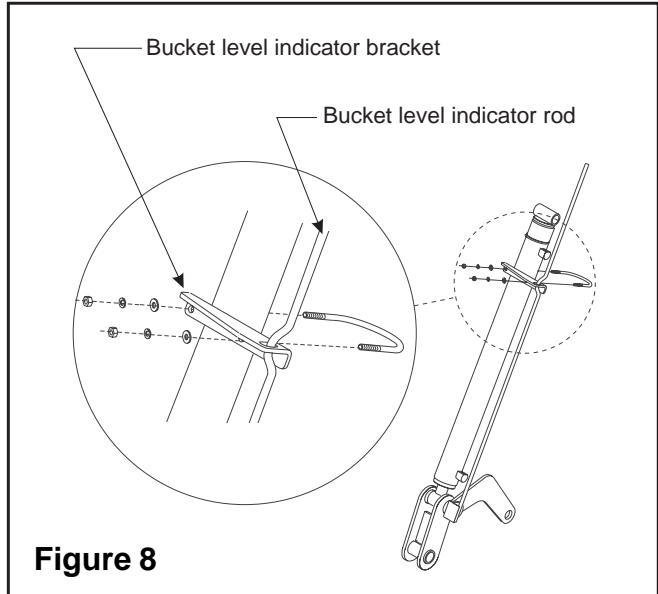

Figure 8

GENERAL TORQUE SPECIFICATIONS

USE THE FOLLOWING TORQUES WHEN SPECIAL TORQUES ARE NOT GIVEN

Standard American and Metric Cap Screws

AMERICAN STANDARD CAP SCREWS										METRIC CAP SCREWS							
SAE Grade	5				8				Metric Class	8.8				10.9			
Typ. Head Markings									Typ. Head Markings								
Cap Screw	TORQUE				TORQUE				Cap Screw	TORQUE				TORQUE			
Size	FT·LBS		N·m		FT·LBS		N·m		Size	FT·LBS		N·m		FT·LBS		N·m	
Inches	MIN	MAX	MIN	MAX	MIN	MAX	MIN	MAX	Millimeters	MIN	MAX	MIN	MAX	MIN	MAX	MIN	MAX
1/4 - 20	6.25	7.25	8.5	10	8.25	9.5	11	13	M6 x 1.00	6	8	8	11	9	11	12	15
1/4 - 28	8	9	11	12	10.5	12	14	16	M8 x 1.25	16	20	21.5	27	23	27	31	36.5
5/16 - 18	14	15	19	20	18.5	20	25	27	M10 x 1.50	29	35	39	47	42	52	57	70
5/16 - 24	17.5	19	23	26	23	25	31	34	M12 x 1.75	52	62	70	84	75	91	102	123
3/8 - 16	26	28	35	38	35	37	47.5	50	M14 x 2.00	85	103	115	139	120	146	163	198
3/8 - 24	31	34	42	46	41	45	55.5	61	M16 x 2.50	130	158	176	214	176	216	238	293
7/16 - 14	41	45	55.5	61	55	60	74.5	81	M18 x 2.50	172	210	233	284	240	294	325	398
7/16 - 20	51	55	69	74.5	68	75	92	102	M20 x 2.50	247	301	335	408	343	426	465	577
1/2 - 13	65	72	88	97.5	86	96	116	130	M22 x 2.50	332	404	450	547	472	576	639	780
1/2 - 20	76	84	103	114	102	112	138	152	M24 x 3.00	423	517	573	700	599	732	812	992
9/16 - 12	95	105	129	142	127	140	172	190	M27 x 3.00	637	779	863	1055	898	1098	1217	1488
9/16 - 18	111	123	150	167	148	164	200	222	M30 x 3.00	872	1066	1181	1444	1224	1496	1658	2027
5/8 - 11	126	139	171	188	168	185	228	251									
5/8 - 18	152	168	206	228	203	224	275	304									
3/4 - 10	238	262	322	355	318	350	431	474									
3/4 - 16	274	305	371	409	365	402	495	544									
7/8 - 9	350	386	474	523	466	515	631	698									
7/8 - 14	407	448	551	607	543	597	736	809									
1 - 8	537	592	728	802	716	790	970	1070									
1 - 14	670	740	908	1003	894	987	1211	1337									

NOTE: These values apply to fasteners as received from supplier, dry or when lubricated with normal engine oil. They do not apply if special graphite or moly sulphide greases or other extreme lubricants are used.

INSTALLATION INSTRUCTIONS