BACKHOE-SKID STEER ADAPTER KIT 95 BACKHOE CASE IH 1840 SKID STEER LOADER

Adapter kit can be installed using tools ordinarily available.

The adapter kit consists of a middle link bracket that bolts to skid steer loader. Another quick attach adapter bolts to backhoe. A middle link pins between backhoe and middle link bracket on skid steer loader. This center link prevents skid steer loader boom from raising and prevents skid steer bucket cylinders from tilting when backhoe is in use. To raise and/or tilt backhoe to get over an obstruction, middle link must be unlatched from skid steer.

INSTALLING MIDDLE LINK BRACKET TO SKID STEER LOADER (Figure 1)

1. Fasten middle link bracket (2) to skid steer loader using 1/2" x 1-3/4" bolts (11), 1/2" lock nuts (13), and backup plate (8). Torque bolts to recommended torque values.

INSTALLING QUICK ATTACH ADAPTER TO BACKHOE

1. Fasten quick attach adapter (1) to backhoe using 3/4" x 2-1/4" bolts (10) and 3/4" lock nuts (14). Torque bolts to recommended torque values.

INSTALLING MIDDLE LINK TO BACKHOE

1. Pin middle link (3) to backhoe upper 3-point pin point using 1" x 3-7/8" clevis pin (15) and 1/4" x 1-1/2" cotter pin (17). Install lock handle (4) into middle link (3) using 1" x 2-1/2" clevis pin (16), 1" x 1-1/2" machinery bushing (19) and 3/16" x 1-1/2" cotter pin (18). Use washer on each side of lock handle inside center link and one outside. Use 3/4" pin (7) and linch pin (20) to secure lock handle open, so middle link (3) can hook over pin in middle link bracket (2) on skid steer. Later this same 3/4" pin will be used to secure lock handle in locked position.

INSTALLING SHIMS ON MIDDLE LINK

1. After hooking backhoe and middle link (3) onto skid steer and with skid steer boom completely lowered, note how much space is between middle link (3) and

top of cross tube in quick attach adapter (1). The appropriate number of shims (5 & 6) should be placed between middle link (3) and cross tube to remove most of this gap. Do not place too many shims in this gap so hook on middle link (3) does not completely set down on pin in middle link bracket (2) on skid steer. Shims are meant only to take up some space and reduce movement of backhoe relative to skid steer loader. Fasten shims to bottom of middle link (3) using 3/8" x 1-1/2" bolts (9) and 3/8" lock nuts (12).

ATTACHING BACKHOE TO SKID STEER

1. Engage skid steer quick coupler into backhoe adapter. Lift backhoe with skid steer boom so adapter middle link (3) clears skid steer middle link bracket (2). Tilt back skid steer coupler to near vertical position and engage lock pins to secure backhoe to skid steer. See step 2 if backhoe is too heavy for skid steer to tilt back.
2. Lower backhoe boom to ground and put backhoe boom control lever into float position (push left lever forward into detent position) to reduce weight on backhoe frame and skid steer. Relieve pressures inside backhoe valve by working handles back and forth. Shut off skid steer and install hydraulic quick couplers to skid steer.
3. Turn on skid steer auxiliary quick couplers to send oil flow to backhoe. Lift backhoe stabilizers slightly off ground. Tilt backhoe slightly forward using loader bucket cylinders and lower loader boom completely down. Tilt backhoe rearward using loader bucket cylinders until middle link (3) is seated onto pin in middle link bracket (2).
4. When middle link is completely seated onto pin, rotate middle link locking handle (4) into lock position and pin with 3/4" pin (7) and linch pin (20).
5. Get on backhoe and take backhoe boom out of float position. Put backhoe into transport position and move to work site.

REMOVING BACKHOE FROM SKID STEER

1. With backhoe boom straight back, extend dipperstick completely out, lower backhoe boom and bucket to ground and put boom control lever into float position.
2. Make sure skid steer boom is completely lowered. Tilt forward and back with skid steer bucket cylinders until middle link locking handle (4) loosens. Remove 3/4" pin from middle link locking handle (4), open locking handle and reinstall 3/4" pin to hold locking handle open.
3. Lift straight up with skid steer boom until middle link hook clears skid steer middle link bracket pin. Some slight adjustments may have to be made with skid steer bucket cylinders if hook hangs up on pin.
4. Important for proper support of backhoe: Get on backhoe. Move backhoe boom control handle out of float position to center neutral position.
5. Lower stabilizers to ground. They will support detached backhoe.
6. Go back into skid steer. Unlock skid steer coupler latching pins. Tilt skid steer coupler forward, lower boom and back skid steer slightly away from backhoe.
7. Lower backhoe to ground by pulling backhoe valve lever to raise stabilizers. Shut off skid steer. Work skid steer auxiliary quick coupler valve back and forth to remove pressure in backhoe and skid steer lines. Uncouple hydraulic hoses.

PARTS LIST - ADAPTER KIT

ITEM	PART NO.	DESCRIPTION	QTY.
1	50355	ADAPTER, QT Assembly	1
2	50426	BRACKET, Middle Link Assembly	1
3	50435	MIDDLE LINK ASSEMBLY	1
4	50359	LATCH ASSEMBLY	1
5	49319-1	SHIM (10GA)	2
6	49319-2	SHIM (7GA)	1
7	49328	PIN, 3/4 x 3	1
8	50356	BACKUP PLATE	2
9	41838-23	HHCS, 3/8-16 x 1.50 YDP	2
10	41838-15	HHCS, 3/4-10 x 2.25 YDP	6
11	41838-12	HHCS, 1/2-13 x 1.75 YDP	6
12	41840-3	NUT, Lock 3/8-16 YDP	2
13	41840-5	NUT, Lock 1/2-13 YDP	6
14	41840-8	NUT, Lock 3/4-10 YDP	6
15	41902-3	PIN, Clevis 1 x 3-7/8 YDP	1
16	41902-4	PIN, Clevis 1 x 2-1/2 YDP	1
17	41903-13	PIN, Cotter 1/4 x 1-1/2 YDP	1
18	41903-8	PIN, Cotter 3/16 x 1-1/2 YDP	1
19	42577-5	BUSHING, Machinery 1 x 1-1/2 YDP	3
20	44756-1	PIN, Linch YDP	1

Figure 1
Adapter Kit

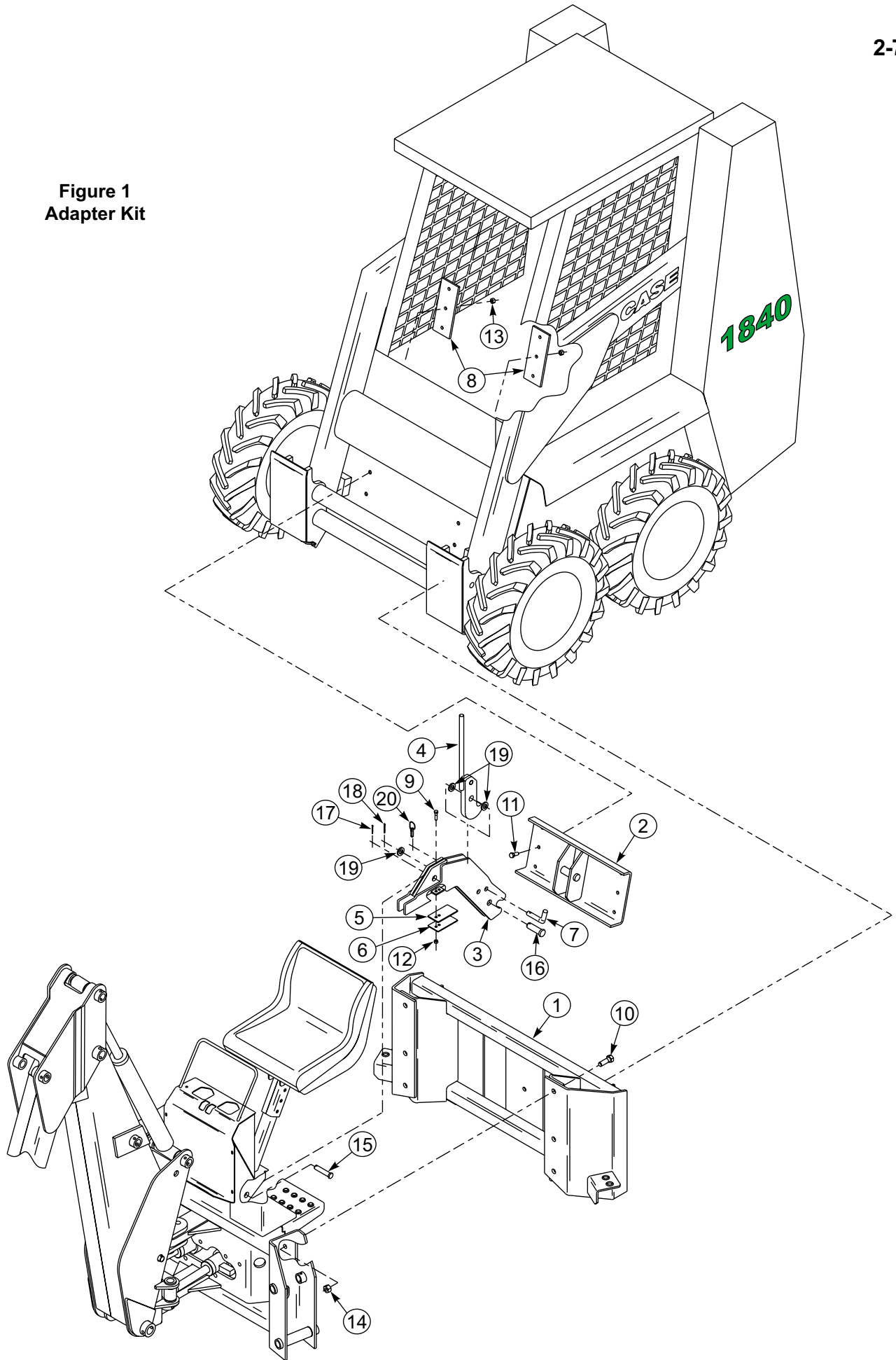

INSTALLATION INSTRUCTIONS