

Keep with Operators Manual

## SMC & RHINO 4211SS LOADER MOUNTING KIT JOHN DEERE TRACTORS

MODEL	2WD	FWA	CAB	LESS CAB
5410	X	X	X	X
5420	X	X	X	X
5510	X	X	X	X
5520	X	X	X	X

Mount kit can be installed using tools ordinarily available. Shut off engine and engage brakes during installation.

**NOTE:** *Leave all attaching hardware loose until loader is completely assembled to facilitate assembly and proper alignment. Torque all hardware to specifications listed in loader operator's manual.*

### TRACTOR PREPARATION

1. Shut off engine and engage brakes during installation of mounting kit.
2. If tractor is equipped with toolbox, it will be necessary to relocate it where it will not interfere with loader.
3. To ease installation, if tractor is equipped with optional front fenders, they may be removed.
4. If tractor is equipped with front weights, they should be removed.
5. Tractor steering stops must be adjusted to provide a minimum clearance of 3/4" between front tire and any part of loader on full left and right lock with front axle fully oscillated. Adjustment must be made with lift cylinders fully retracted. Refer to tractor operator's manual for steering stop adjustment.
6. Check that tractor line, which is located directly forward of upper bolt hole pattern on tractor fly wheel casting on right side of tractor, is properly placed in groove provided in casting. This will prevent possible damage to tractor line from loader midmounting (see Figure 1).

### INSTALLING LOADER MOUNTING BRACKETS (Figure 1)

**NOTE:** *Unless specified, leave all attaching hardware loose until mounting brackets are completely installed to facilitate assembly and proper alignment of mounting brackets.*

1. Attach left and right midmountings (1 & 2) to bolt hole pattern in tractor fly wheel casting using 20MM x 50MM cap screws (4) and lock washers (7).
2. Attach midmountings (1 & 2) to rear bolt hole pattern of front tractor casting using 16MM x 65MM cap screws (6), lock washers (8), flat washers (9), and spacers (3) in recessed bolt hole of tractor casting as shown in figure 1. Finish securing midmountings to front tractor casting using 16MM x 45MM cap screws (5), lock washers (8) and flat washers (9).

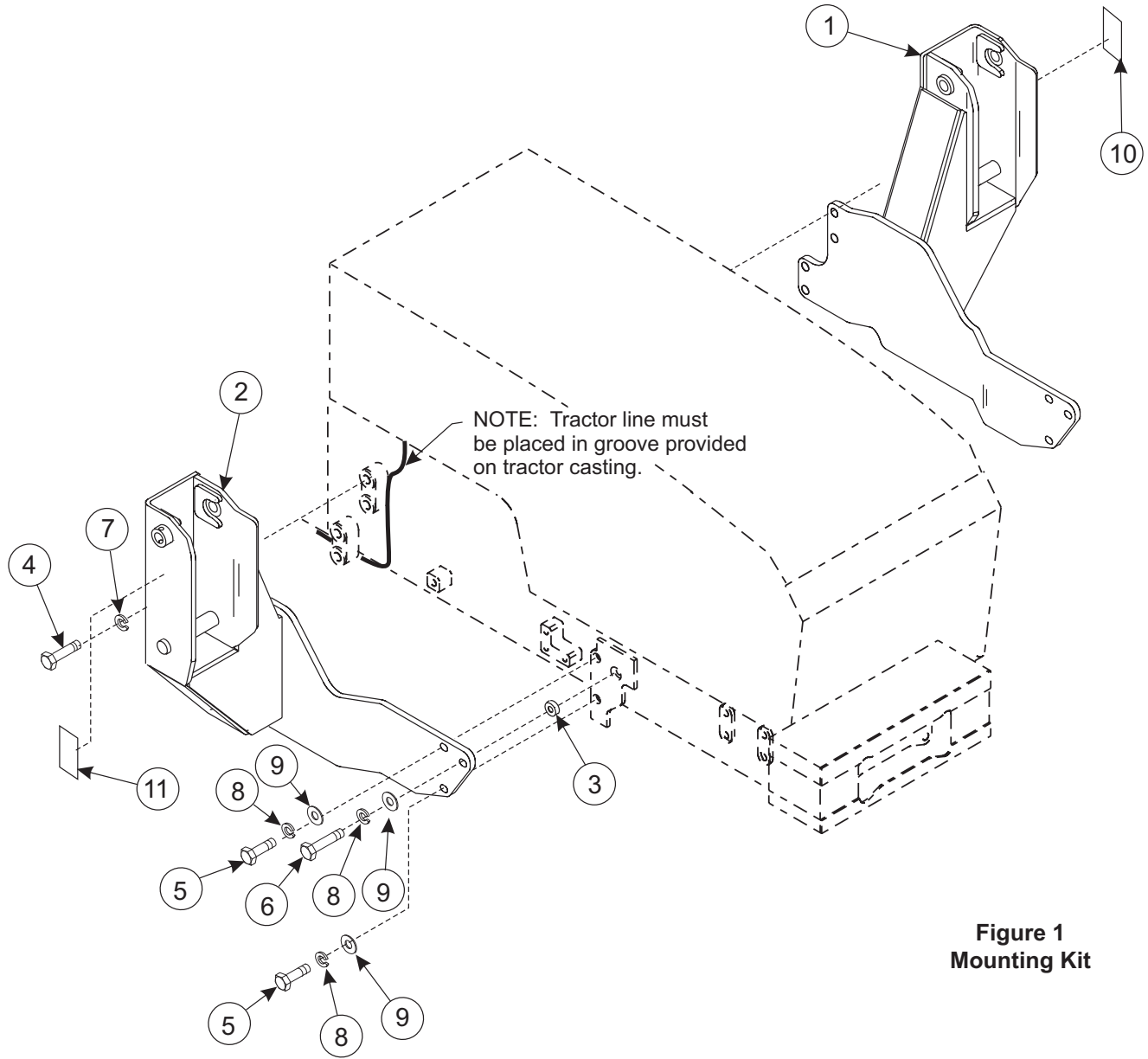

Figure 1  
Mounting Kit

**PARTS LIST - MOUNTING KIT**

ITEM	Part No.	DESCRIPTION	QTY.
1	49714-1	BRACKET, Mid Mounting, Left, with Decal	1
2	49714-2	BRACKET, Mid Mounting, Right, with Decal	1
3	49706-1	SPACER	2
4	42672-37	SCREW, Cap, 20MM-2.50 x 50MM	8
5	42672-21	SCREW, Cap, 16MM-2.00 x 45MM	4
6	42672-52	SCREW, Cap, 16MM-2.00 x 65MM	2
7	48093-2	WASHER, Lock, 20MM	8
8	41837-7	WASHER, Lock, 5/8	6
9	42502-12	WASHER, Flat, 5/8	6
10	46776	DECAL, Warning	1
11	48436	DECAL, Warning	1



**WARNING:** Loader must be supported before removing hardware securing loader to the shipping pallet, or the loader will tip over.

### MOUNTING 4211SS LOADER (Figures 2, 3 & 4)



**WARNING:** To avoid injury during installation of quick attach loader, do not permit bystanders within ten feet of loader.



**WARNING:** To avoid injury during installation of quick attach loader, an overhead hoist must be used for initial mounting. Parking stands are not operational without attachment mounted.

1. Loop chain under each bucket cylinder and hook on loader boom arm (see figure 2A). Using overhead hoist to support loader, remove cotter pins (A), hitch pins (B) and lynch pins (C) (see figure 3). Discard only the cotter pins. Then remove hardware securing loader to pallet. Lift loader.

Figure 2

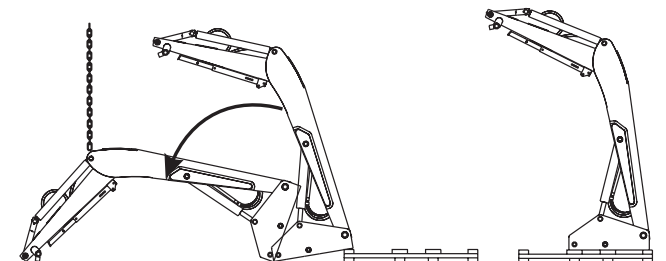
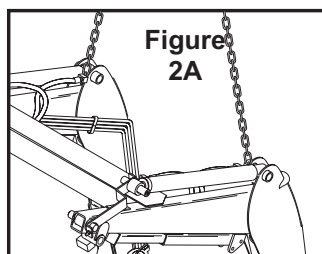

**CAUTION:** Loader uprights may rotate downward when loader is lifted from pallet.

2. Position pallet at rear of loader to facilitate lowering (see figure 2). Lower loader from vertical shipping position to horizontal position (scraps of cardboard may be used to protect paint). Remove 3/8 cap screws (D), lock nuts (E), pins (F), shipping brackets (G). Discard shipping brackets, retain hardware for further use. Remove bucket level indicator rod attached to oil lines for shipment.

3. Remove tie straps (H) from hydraulic hoses. Route hoses through hose loop (I) on inside of loader upright (refer to figure 3). Secure a hoist strap around the boom arm assembly or secure with a chain hook into hole (J), if so provided in underside of boom arm (see figure 3). If using a strap, the strap should be located around the boom arm in about the same location as the chain shown in figure 4. Be sure to keep strap under the oil lines on the right side of the boom.

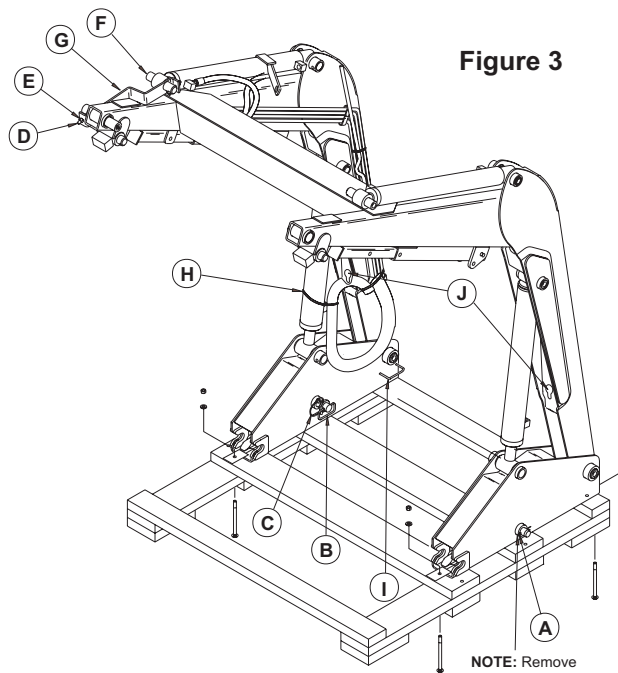

Raise loader with overhead hoist as shown in figure 4.

Figure 4

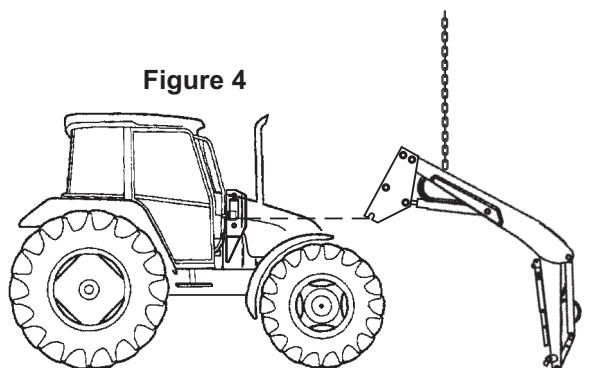

**NOTE:** If the tractor is not equipped with mid-mount couplers, hose kit 2-6859 needs to be installed before completing the next step.

(Continued on Page 4)

## 2-6977



**WARNING:** Loader must be supported before removing hardware securing loader to the shipping pallet, or the loader will tip over.

### MOUNTING 4211SS-MSL LOADER (Figures 5, 6 & 7)



**WARNING:** To avoid injury during installation of quick attach loader, do not permit bystanders within ten feet of loader.



**WARNING:** To avoid injury during installation of quick attach loader, an overhead hoist must be used for initial mounting. Parking stands are not operational without attachment mounted.

1. Loop hoist strap or chain around crossmember (see figure 5A). Using overhead hoist to support loader, remove shipping angle braces (C) (figure 6) by removing 1/2" lock nut (A), lift off brace (C), then replace 1/2" lock nut (A). **NOTE:** There is an additional 1/2" flat washer on outside of brace for shipping only, remove and discarded with shipping angle brace.

Figure 5

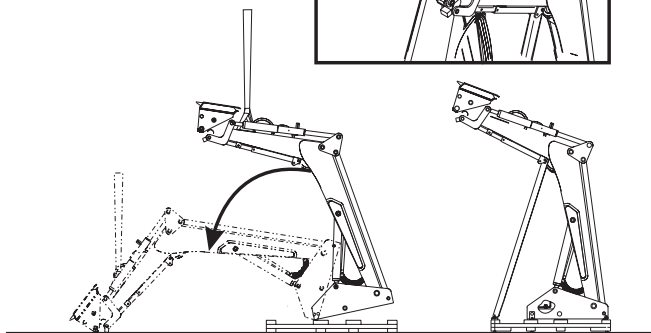
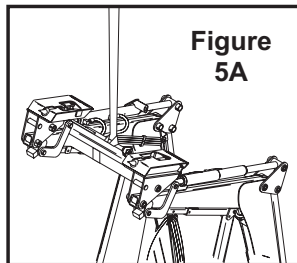

**NOTE:** Do not over tighten lock nut (A). Parking stand tube must pivot freely.

Remove remaining hardware (D) from shipping braces (C) and discard braces and hardware.

Remove cotter pins (E), hitch pins (G) and lynch pins (F)(see figure 6). Discard only the cotter pins. Then remove nuts and washers (D) from bolts securing loader to pallet.

2. Lower loader from vertical shipping position to horizontal position (figure 5) (Loader may require slight push to start lowering). Packaging hardware may bend during lowering process, which is acceptable. Remove bucket level indicator rod attached to oil lines for shipment.

Figure 6

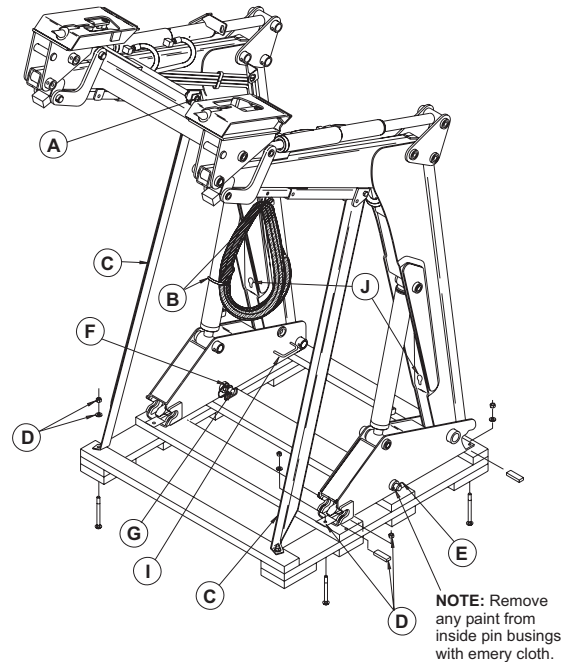

**NOTE:** Remove any paint from inside pin busings with emery cloth.

3. Remove tie straps (B) from hydraulic hoses. Route hoses through hose loop (I) on inside of loader upright (refer to figure 6). Secure a hoist chain hook into hole (J) provided in boom underside (refer to figures 6 & 7).

Raise loader with overhead hoist as shown in figure 7.

**NOTE:** If the tractor is not equipped with mid-mount couplers, hose kit 2-6859 needs to be installed before completing next step.

Figure 7

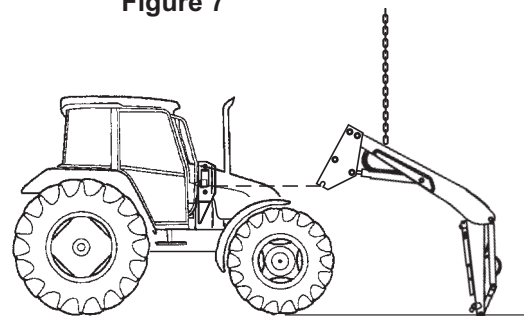

## MOUNTING 4211SS-MSL & 4211SS LOADERS (Continued)

**NOTE:** Examine pin bushings and remove any paint with emery cloth before mounting loader (see figures 1, 3 & 6).

**NOTE:** Before continuing mounting procedure, lubricate loader as instructed in loader manual.

4. A) If the tractor is not equipped with mid-mount couplers, back tractor up to rear of loader. Attach lift cylinder function hoses (color coded green and yellow) to tractor rear remotes. Retract lift cylinders fully and continue to activate control lever for approximately 10 seconds.

B) If tractor is equipped with mid-mount couplers, park tractor next to loader so right side of tractor cab window is parallel with rear of loader upright. Attach colored spiral bands to tractor female couplers to identify hoses (Refer to Figure 9). Attach lift cylinder function hoses (color coded green and yellow) to corresponding tractor couplers. Retract lift cylinders fully and continue to activate control lever for approximately 10 seconds.

**NOTE:** Important to attach lift cylinder hoses (yellow and green spiral band coded) for loader to function properly.

Extend lift cylinders about 2" from the fully closed position. Shut off tractor and disconnect hydraulic hoses.

Position tractor directly behind loader. Slowly raise loader with overhead hoist until loader upright will clear tractor front tires.

5. Move tractor forward until loader upright saddles are centered over mounting shaft. Lower loader with overhead hoist until upright saddle straddles mounting shaft.

Figure 8

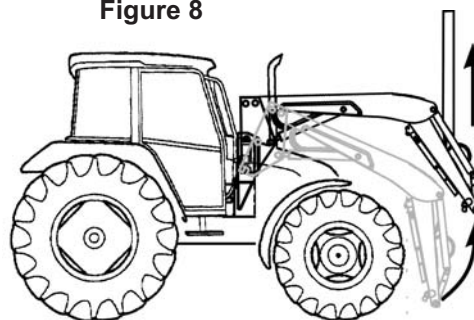

6. Remove hoist chain or strap from loader boom and secure around front crossmember (Refer to Figure 8). Using overhead hoist raise front of loader to rotate loader upright into mounting pocket. Continue to rotate loader upright until upright has fully rotated into back of mounting guide. Insert two 1x 7-3/4 pins and linch pins which were removed from loader uprights in step 1, to secure loader to loader mountings.
7. Connect hoses to tractor hydraulics. Refer to hose kit instructions (2-6859) for tractors using rear remotes.
8. Start engine and slowly cycle cylinders several times to purge air from hydraulic system. Replenish hydraulic system using New Holland 134 hydraulic oil.
9. Adjust front wheel tread settings or steering stops, if necessary to provide a minimum 3/4 inch clearance between front tires and any part of loader with lift cylinders fully retracted and front axle fully oscillated. Be sure lift cylinders are fully retracted. Refer to tractor operator's manual for tread setting and steering stop adjustment procedures.

## INSTALLING BUCKET OR ATTACHMENT

Refer to loader operator's manual to install bucket or optional attachment.

## ATTACH BUCKET LEVEL INDICATOR

Refer to instruction sheet and assembly manual with bucket or optional attachment.