

715727006 72" STD.
 715727026 72" STD.
 715729006 60" H.D.
 715729066 60" H.D.
 715730006 72" H.D.
 715730066 72" H.D.
 715737006 84" H.D.
 715737026 84" H.D.
 716652006 84" S & LM
 716652016 84" S & LM
 716652026 84" S & LM

ASSEMBLY MANUAL

Keep With Operator's Manual

2-6617
 2-6939
 2-6611
 2-6938
 2-6588
 2-6940
 2-6612
 2-6941
 2-6619
 2-6682
 2-6943

QUICK ATTACH MATERIAL BUCKETS

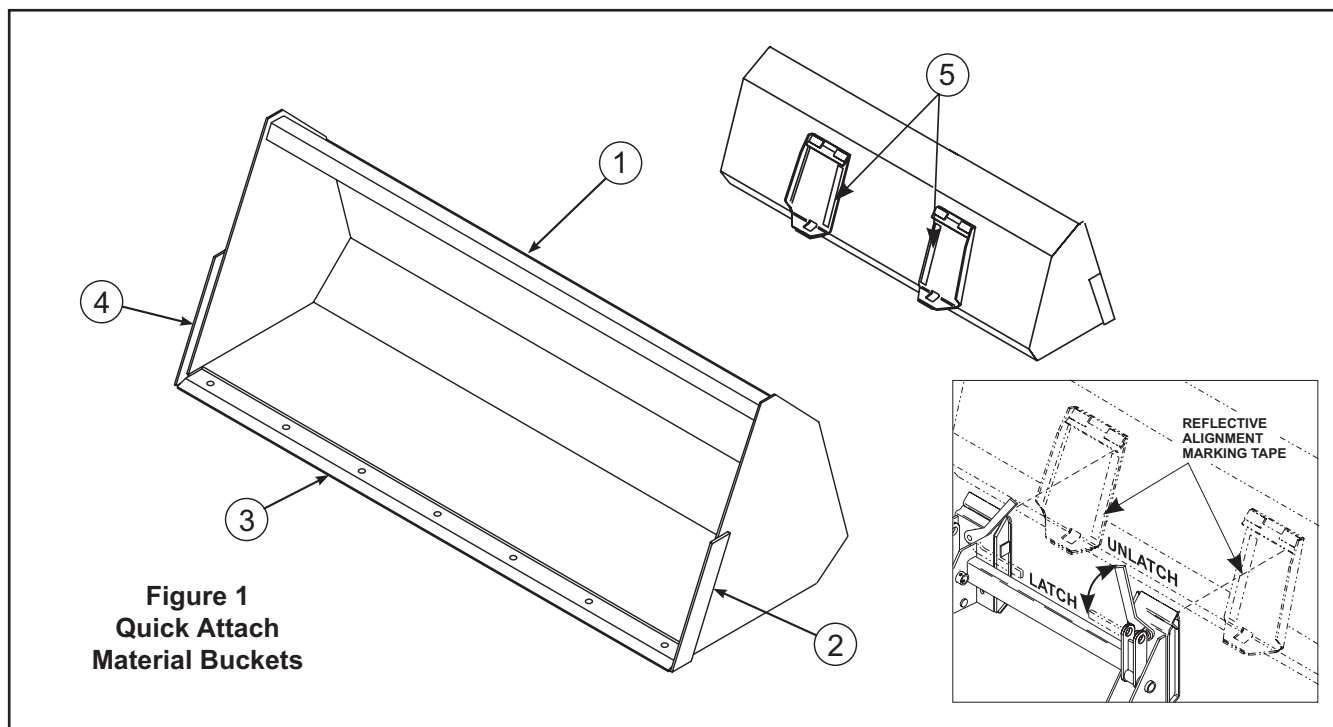

Figure 1
 Quick Attach
 Material Buckets

PARTS LIST - MOUNTING KIT

ITEM	SMC NO.	NH NO.	DESCRIPTION	QTY.
1	*	*	BUCKET, 72" Standard Quick Attach (Includes cutting edges)	1
	*	*	BUCKET, 60" Heavy Duty Quick Attach (Includes cutting edges)	1
	*	*	BUCKET, 72" Heavy Duty Quick Attach (Includes cutting edges)	1
	*	*	BUCKET, 84" Heavy Duty Quick Attach (Includes cutting edges)	1
	*	*	BUCKET, 84" Snow & Light Material Quick Attach (Includes cutting edges)	1
2	28086-1	SML280861	CUTTING EDGE, Left Side (60" H.D., 72" H.D., 84" H.D.)	1
	32817-1	SML328171	CUTTING EDGE, Left Side (72" Standard & 84" Snow & Light Material)	1
3	22542-5	SML225425	CUTTING EDGE, Bottom (72" Standard, no holes)	1
	46734-3	SML467343	CUTTING EDGE, Bottom (60" Heavy Duty, with holes)	1
	46734-1	SML467341	CUTTING EDGE, Bottom (72" Heavy Duty, with holes)	1
	46734-2	SML467342	CUTTING EDGE, Bottom (84" Heavy Duty, with holes)	1
	22542-8	SML225428	CUTTING EDGE, Bottom (84" Snow & Light Material, no holes)	1
4	28086-2	SML280862	CUTTING EDGE, Right Side (60" H.D., 72" H.D., 84" H.D.)	1
	32817-2	SML328172	CUTTING EDGE, Right Side (72" Standard & 84" Snow & Light Material)	1
5	46979-1	86582385	TAPE, Reflective, Alignment, White, 14"	2

* Not sold as repair part.

ATTACHING QUICK ATTACH MATERIAL BUCKETS

No tools are needed to install quick attach material buckets. Loader must be equipped with quick attach device (716653006, 716653016 or 716653116).



WARNING: To avoid injury during attachment or detachment, do not allow bystanders within 10 feet of loader or attachment.

1. Locate tractor and attachment on level ground. Lower boom to rest on the ground. Extend the bucket cylinders slightly, while raising the boom to provide three to five inches of ground clearance, drive the tractor ahead slowly toward the attachment, aligning the loader quick attach device.

NOTE: To help guide loader quick attach device into attachment, alignment reflective tape (5) has been applied to back of attachment as shown.

2. While driving the tractor ahead slowly to maintain contact with the attachment, activate the lift cylinders to raise the loader until the quick attach engages under the attachment lip.
3. Then activate bucket cylinders to retract, continuing to roll the attachment back completely.
4. Place tractor in neutral, set parking brake, shut off tractor. Move latch pin handles to latch (down) position.
5. Start tractor activate lift cylinders to raise attachment one or two feet off the ground and extend bucket cylinders to tilt attachment at a slight downward angle, so quick attachment latch pins are visible. Visually inspect the attachment mechanism to verify that the pins are engaged through the latch plate on the back of the attachment.

NOTE: If the attachment is not securely attached, follow the instructions for detaching it and repeat the above procedure.

DETACHING QUICK ATTACH DEVICE



WARNING: To avoid injury during installation of the loader attachment, do not allow bystanders within 10 feet of loader or attachment.

1. Locate tractor and loader on level ground.
2. Lower boom arms until the attachment is level and resting on ground.
3. Place tractor in neutral, set parking brake, shut off tractor engine and disengage quick attach device latch pins by moving handles to unlatch position.
4. Start tractor engine, release brake and extend bucket cylinders while slowly backing the tractor away from attachment, until quick attach disengages from attachment.

BUCKET MODEL	BUCKET WIDTH		STRUCK CAPACITY	
	Inches	Centimeters	Cubic Yards	Cubic Meters
72" Standard	72	183	.44	.34
60" H.D.	60	152	.44	.34
72" H.D.	72	183	.55	.42
84" H.D.	84	213	.63	.48
84" Snow & Light Material	84	213	.68	.52

INSTALLATION INSTRUCTIONS