

Keep With Loader Operator's Manual

**QUICK ATTACH BALE SPEAR  
NEW HOLLAND 7411, 7312 & 7314 LOADERS  
SMC 114Q, 2412, & 2414 LOADERS**

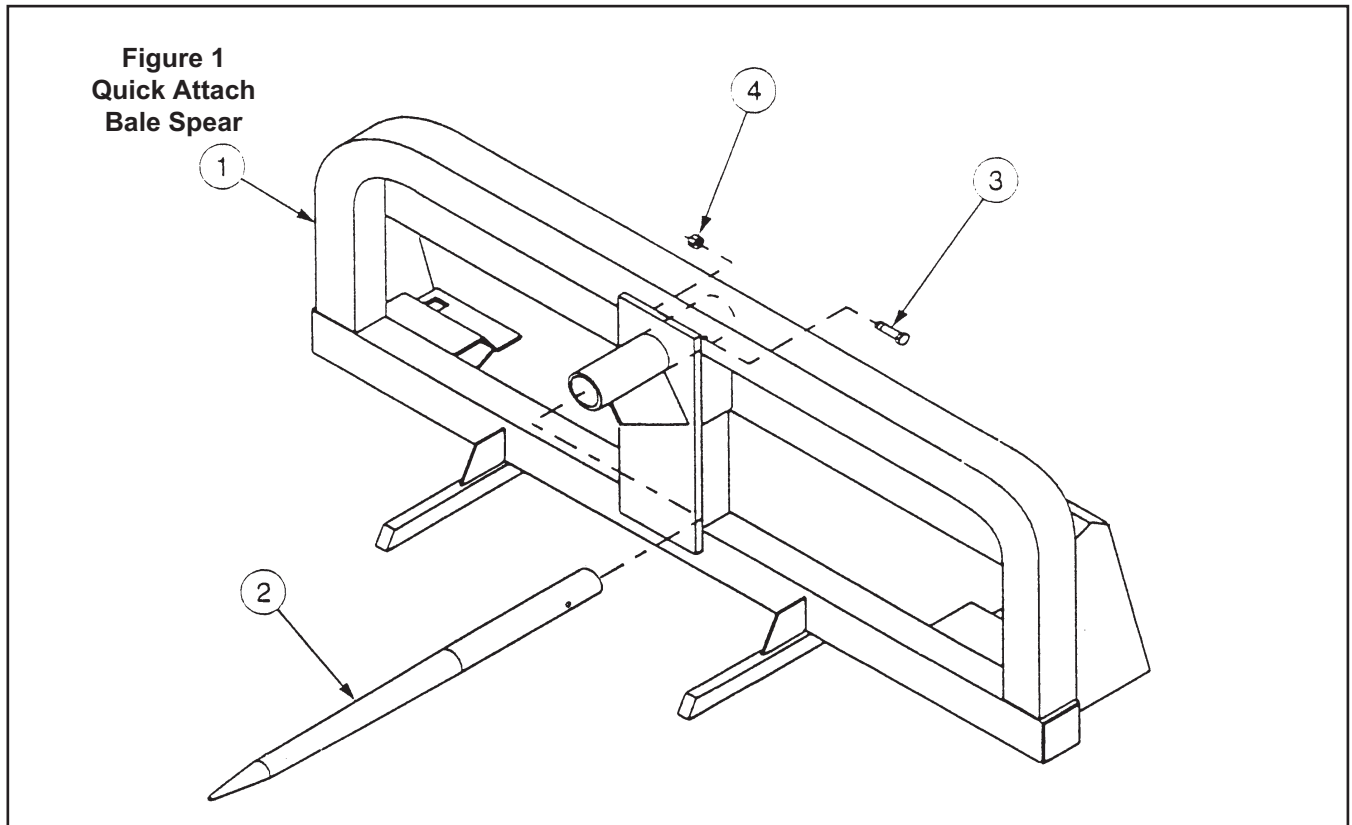

**Figure 1  
Quick Attach  
Bale Spear**

Bale spear can be assembled using tools ordinarily available. Loader must be equipped with quick attach device.

**NOTE:** Refer to loader operator's manual for instructions on attaching bale spear to loader

**ASSEMBLING ROUND BALE SPEAR (Figure 1)**

1. Remove banding which secures bale spike (2) to bale spear attachment bracket (1). Temporarily remove 1/2 x 3-1/4 cap screw (3) and lock nut (4).
2. Place spike (2) into sleeve of bale spear bracket (1). Fasten spike to bracket using 1/2 x 3-1/4 cap screw (3) and lock nut (4).



**WARNING:** Keep bales, bale spear and loader boom clear of overhead lines. Allowing loader boom or any attachment to contact overhead lines may electrify entire tractor and Kill (electrocute) operator.

**PARTS LIST - MOUNTING KIT**

ITEM	PART NO.	DESCRIPTION	QTY.
1	*	BRACKET, Round Bale Spear (Not sold as a repair part)	1
2	40906	SPIKE, Round Bale Spear	1
3	G180191	SCREW, Cap, 1/2-13 x 3-1/4	1
4	G9414074	NUT, Lock, 1/2-13	1

\* Not sold as repair part.

## ATTACHING QUICK ATTACH BALE SPEAR

No tools are needed to install quick attach bale spear.



**WARNING:** To avoid injury during attachment or detachment of round bale spear, do not allow bystanders within 10 feet of loader or bale spear.

1. Locate tractor, loader and bale spear on firm level ground. Lower boom to three to five inches off ground.
2. Disengage latch pins by lifting handles and pulling them rearward, so latch pins are held in raised posi-

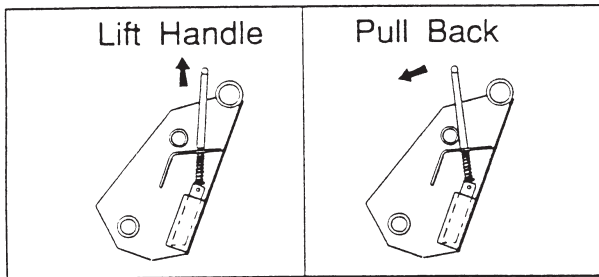

tion.

3. Extend bucket cylinders slightly. Making sure loader quick attach bar is parallel to bucket, drive tractor ahead very slowly toward bucket until quick attach bar touches attachment just below attachment channel.
4. Use lift cylinder to raise loader while activating bucket cylinder to curl quick attach device to engage channel of bale spear. Moving tractor forward will assist engagement.

7314, 7411, & 7412 Loaders- When quick attach bar has fully engaged channel, continue to retract bucket cylinder until latch pins engage securely.

7312 Only- When quick attach bar has fully engaged channel; shut off engine, engage brakes and manually engage quick attach device.

5. Tilt bale spear at a slight downward angle, so quick attach device is visible and inspect attachment mechanism to verify that pins are fully engaged in ears on back of bale spear.

**NOTE:** If bale spear is not securely attached, follow instructions for detaching bale spear and repeat above procedure

## DETACHING QUICK ATTACH BALE SPEAR

**IMPORTANT:** Loader must be equipped with a bucket, bale spear or similar attachment to dismount loader from tractor.

1. Locate tractor and bale spear on firm level ground.
2. Lower boom arms with bale spear level until bale spear rests two to three inches off the ground. Shut off tractor engine and set tractor brakes.
3. Disengage latch pins by lifting handles and rotating them so pins rest on blocks provided on attachment ears.
4. Start tractor engine, release tractor brakes and extend bucket cylinders while slowly backing tractor away from bale spear, until quick attach bar disengages from bale spear.

# INSTALLATION INSTRUCTIONS