

Keep With Loader Operator's Manual

SMC 2410 VALVE AND PLUMBING KIT INSTRUCTIONS KUBOTA TRACTORS

MODEL	2WD	4WD	LESS CAB	WITH CAB
M4700		X	X	
M5400		X	X	

Valve and plumbing kit can be installed using tools ordinarily available. Valve control handle has been factory preassembled for ease of installation. Shut off engine and engage brakes during installation.

NOTE: Apply sealant only to all tapered threads unless coupled with swivel adapters. When using teflon tape, wrap tape clockwise (as viewed from end) and wrap only twice. Keep sealant away from first two threads of tapered end to prevent contamination of hydraulic fluid. Do not use sealant on o-ring or flare adapter threads.

ATTACHING VALVE TO LOADER MOUNTING BRACKET (Figures 1 & 3)

1. Install 3/4 x 9/16 elbow fitting (9) to valve (1). Install adapter fittings (22), female quick couplers (15) and 1" colored bands (16) to working ports of valve (1).
2. Fasten valve mounting plate (23) to valve mounting bracket (24) using 3/8 x 2-1/4 cap screws (2) and 3/8 lock nuts (5).
3. Fasten valve (1) to valve mounting plate (23), with power beyond port on the bottom, using 5/16 x 3/4 cap screws (6) and 5/16 lock washers (7)(Figure 1).
4. Fasten decal mounting plate (4) to valve (1) using 5/16 x 3/4 cap screw (6) and 5/16 lock washer (7). Making sure surface of decal mounting plate is clean and dry, remove backing from decal (20) and apply it to decal mounting plate.
5. Thread nut (13) onto handle (3). Attach handle (3) and handle extension (23)(If needed) to valve (1). Slip boot (14) over handle and cover handle assembly. Attach ball (8) to handle.



WARNING: Escaping hydraulic fluid under pressure can penetrate skin causing serious injury.

- DO NOT use your hands to check for leaks. Use a piece of cardboard or paper to search for leaks.
- Stop engine and relieve pressure before connecting or disconnecting lines.
- Tighten all connections before starting engine or pressurizing lines.

If any fluid is injected into skin, obtain medical attention immediately or gangrene may result.

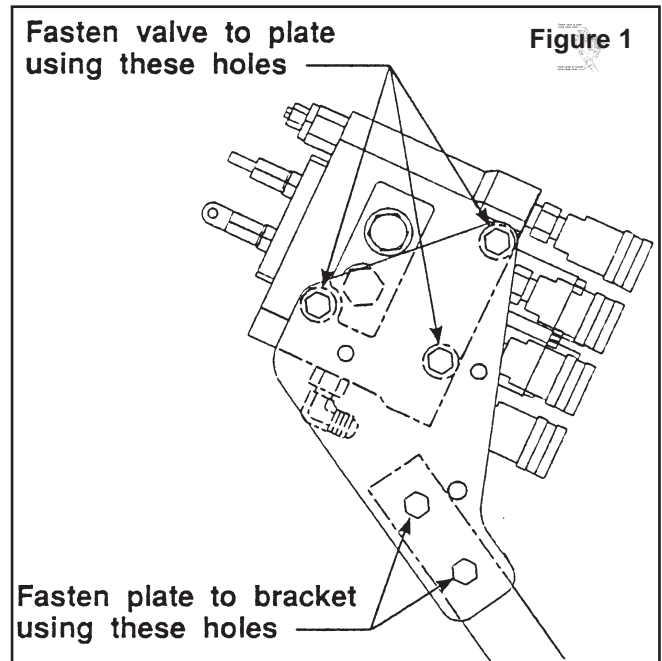

2-6339

PLUMBING CONTROL VALVE TO TRACTOR HYDRAULICS (Figures 2 & 3)

1. Install 3/8 x 65 hose (11) to elbow fitting (9) in power beyond port of valve (1).
2. Install 3/8 x 70 hose (27) to pressure port in valve (1). Install 3/8 x 40 hose (12) to tank port in valve (1).
3. Route hoses (11 & 27) under operators platform and back to ports on hydraulic block. Route tank hose (12) to tank port on side of transmission.
4. Remove hydraulic block and O-rings from right side of transmission casting. Remove plug from tank port on right side of transmission casting.

NOTE: To make installation to pressure and power beyond ports easier, support rear of tractor and remove right side wheel and tire.

5. Install 9/16 x 1/2 elbow fitting (28) to tank port on side of transmission. Point elbow fitting (28) toward front of tractor.
6. Install 3/8 NPTF x 9/16 JIC straight fittings (25) and 9/16 JIC x 45° adapter fittings (26) to pressure and power beyond ports. Point 45° adapter fittings (26) forward.

NOTE: Plug unused port using appropriate plug (Not supplied).

7. Connect power beyond hose (11) to power beyond port in tractor hydraulic block. Connect pressure hose (27) to pressure port in tractor hydraulic block. Connect tank hose (12) to tank port in tractor transmission.
8. Secure hoses (11 & 12 & 27) to steel hydraulic line using plastic tie straps (21).

PLUMBING LOADER TO CONTROL VALVE

1. Install 3/8 x 44 hoses (17) onto boom oil line tubes. Install and tighten hose fittings one at a time from bottom up. Loosening closest oil line clamp will ease installation.
2. Install male quick couplers (19) onto free ends of hoses (17). Install 5/8 spiral bands (18) onto free ends of hoses (17) to match bands (16) on female quick couplers.

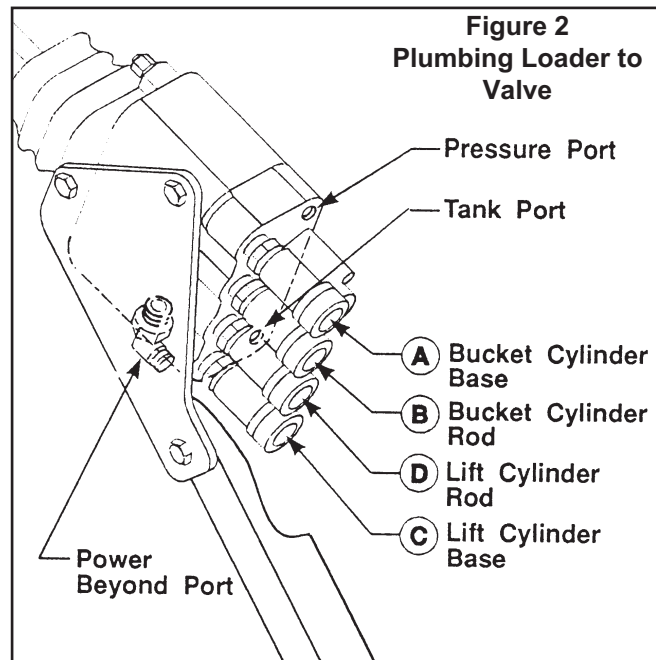

3. Connect hoses from upper two boom oil lines to upper female quick couplers and connect hoses from lower boom oil lines to lower two female quick couplers (Figures 2 & 3). Bundle hoses together using plastic tie strap (21).

4. After all plumbing has been completed and all parts are secure, start engine and slowly cycle lift and bucket cylinders several times to purge air out of system, then retract cylinders and shut off tractor engine. Add additional tractor hydraulic fluid as specified in tractor owners manual to bring level of hydraulic fluid up to full.

NOTE: When cycling loader, operate loader according to operation decal (20) on valve box. If direction of control lever is wrong, or loader will not lower, recheck connections shown.



WARNING: Escaping hydraulic fluid under pressure can have sufficient force to penetrate skin causing serious personal injury. If injured by escaping hydraulic fluid, obtain medical treatment immediately.

ITEM	PART NO.	DESCRIPTION	QTY.
1	51032	VALVE, Prince LVR (2000 PSI)	1
2	41838-19	SCREW, Cap, 3/8-16 x 2-1/4	2
3	43517	HANDLE, Standard	1
4	43451	ANGLE, Decal Mounting	1
5	41840-3	NUT, Lock, 3/8-16	2
6	41838-26	SCREW, Cap, 5/16-18 x 3/4	4
7	41837-2	WASHER, Lock, 5/16	4
8	38902	BALL, Handle 1	1
9	32845-7	FITTING, Elbow, 9/16-18 JIC x 3/4-16 O-Ring, 90°	1
10	41776	EXTENSION, Handle	1
11	36386-16	HOSE, 3/8 x 65 (Power Beyond)	1
12	43454-1	HOSE, 3/8 x 40 (Tank)	1
13	G271506	NUT, Hex, 7/16-20	1
14	43635	BOOT 1	1
15	6147-4	COUPLER, Female	4
16	36240-9	SPIRAL BAND, Plastic, Blue, 1"	1
	36240-10	SPIRAL BAND, Plastic, Red, 1"	1
	36240-11	SPIRAL BAND, Plastic, Yellow, 1"	1
	36240-12	SPIRAL BAND, Plastic, Green, 1"	1
17	36336-12	HOSE, 3/8 x 50 4	4
18	36240-5	SPIRAL BAND, Plastic, Blue, 5/8	1
	36240-6	SPIRAL BAND, Plastic, Red, 5/8	1
	36240-7	SPIRAL BAND, Plastic, Yellow, 5/8	1
	36240-8	SPIRAL BAND, Plastic, Green, 5/8	1
19	6137-4	COUPLER, Male 4	4
20	43453	DECAL, Single Handle Control	1
21	8137-1	STRAP, Adjustable	2
22	39280-7	FITTING, Adapter, 3/4-16 O-Ring x 3/8 NPT	4
23	43450	PLATE, Valve Mounting	1
24	44180	BRACKET, Valve Mounting	1
25	31221-4	FITTING, Adapter, 3/8 NPTF x 9/16 JIC, Straight	2
26	38226-1	FITTING, Adapter, 9/16 JIC, 45°	2
27	43454-8	HOSE, 3/8 x 70 (Pressure)	1
28	39609-7	FITTING, 1/2-14 NPTF x 9/16 JIC, 90°	1
29	41838-25	SCREW, Cap, 1/2-13 x 2-1/2	2
30	42502-10	WASHER, Flat, 1/2	2
31	41837-5	WASHER, Lock, 1/2	2

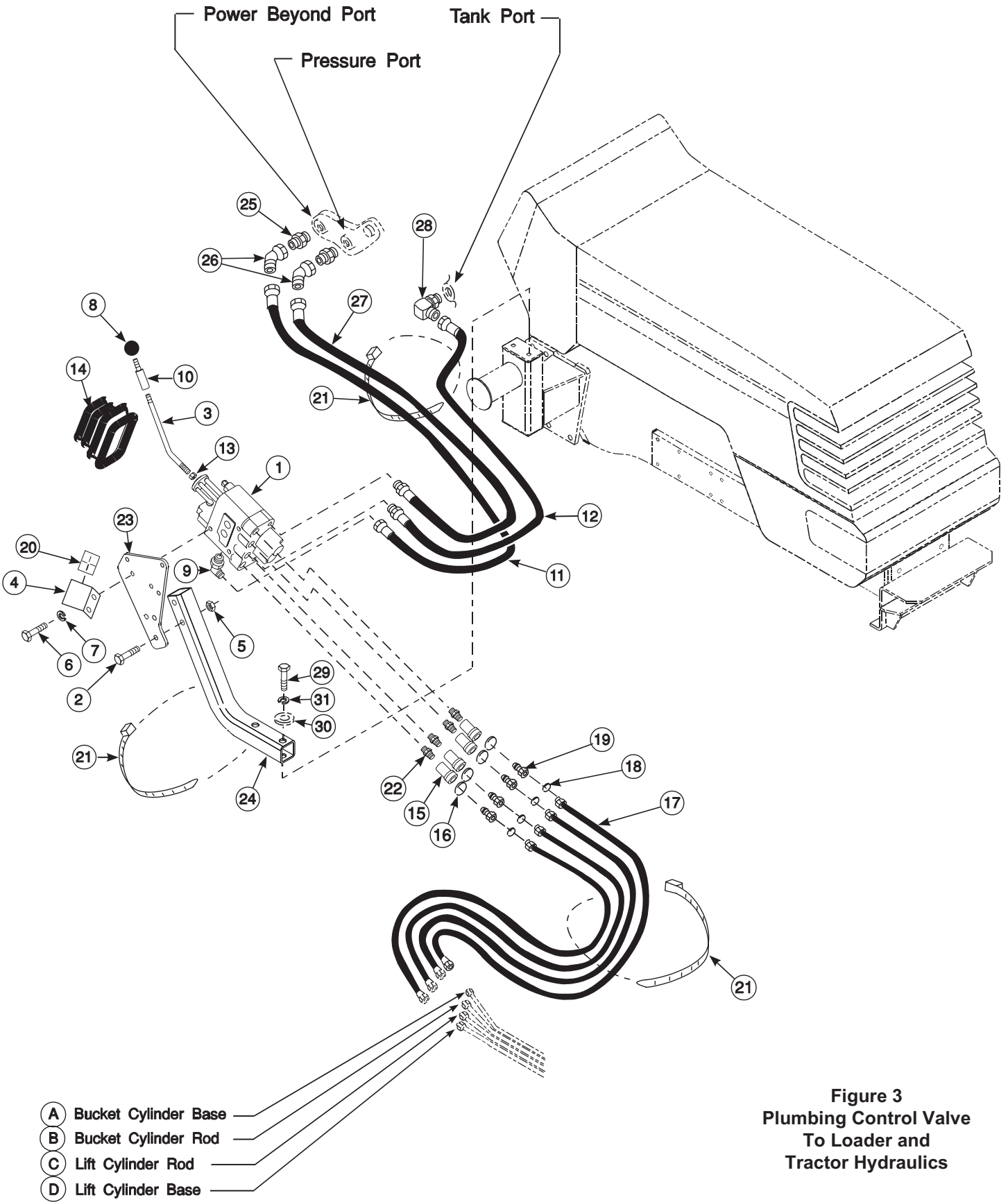

Figure 3
Plumbing Control Valve
To Loader and
Tractor Hydraulics

PRINCE LVR VALVE SERVICE

Following is an outline procedure for disassembling and reassembling valve.



WARNING: *The valve has a valve relief setting pre-set at the factory. Tampering with this setting can cause serious injury to operator and damage to tractor or loader. Unauthorized adjustments or service to valve relief will VOID WARRANTY of both loader and tractor. If adjustments or service to valve relief are required during warranty period, an authorized service department must be consulted for authorization.*

VALVE DISASSEMBLY (Figure 4)

NOTE: *It is advisable to mark or tag all parts so they will be reinstalled in their proper position.*

1. Slide boot (6) to top of handle (34). Remove hex head cap screws (36) from rod ends (9 & 10). Remove handle with boot and adapter plate (8). Remove nuts (28) from spool stud (7) and rod end assemblies (10). Remove spool stud (7) and rod end assemblies (10) from valve.

NOTE: *Spool adapters (33) are factory assembled. Removal from spools is not necessary. If replacing a damaged adapter, clean threads with loctite primer and install using loctite 262.*

2. Remove hex head cap screws (13) and detent end caps (14) from both spools. Remove detent sleeve (12) from regen spool. Remove steel balls (20), poppet (21) and poppet spring (19) from detent retainer (24). Remove retaining flat (15) and detent spacer (16) from regen spool.
3. Secure handle end of regen spool. Using a rod through retainer ball holes, remove detent retainer (24) from regen spool.

NOTE: *Detent retainers (18 & 24) are installed on spools using Loctite 222 or equivalent. If spool adapter comes loose instead of detent retainer, pull spool completely out of valve and secure spool using vice grips on land section of spool not machined for valve bore.*

4. Remove washer (17), centering spring (26) and stop cup (23) from regen spool.
5. Holding in on float detent sleeve (22), push in on float spool from handle end and remove steel balls (20) from float detent retainer (18). Remove float detent sleeve (22), poppet (21), poppet spring (19), retaining flat (15) and spacer (16) from float spool.

6. Secure handle end of float spool. Using a rod through retainer ball holes, remove detent retainer (18) from float spool.

NOTE: *Detent retainers (18 & 24) are installed on spools using Loctite 222 or equivalent. If spool adapter comes loose instead of detent retainer, pull spool completely out of valve and secure spool using vice grips on land section of spool not machined for valve bore.*

Remove washer (17), centering spring (26) and stop cup (23) from float spool.

7. Push spools in from handle end until rear spool seals (1) are exposed. Using wire hook and screwdriver remove rear spool seals. Push spools in from the rear until front spool seals (1) are exposed. Using wire hook and screwdriver remove front spool seals.
8. Clean all parts, including valve body, in suitable cleaning solvent. After cleaning parts with solvent, use air pressure to blow any dirt or excess solvent from all parts including inside of valve body.

VALVE REASSEMBLY

1. Examine all parts for wear and damage and replace if necessary.
2. Lubricate all o-rings and spools with oil to prevent damage when assembling.
3. Lubricate all detent and spring centering parts with a light coat of grease before assembling.
4. Reassemble all parts in reverse order of disassembly.

NOTE: *Use Loctite 222 or equivalent when installing detent retainers (18 & 24).*

RELIEF VALVE, LOAD CHECK PLUGS and POWER BEYOND SLEEVE

NOTE: *Relief valve (3), load check plugs (27) and power beyond sleeve (2) may be removed separately to clean inspect or replace parts without removing valve spools.*

NOTE: *If repairing or replacing relief valve (3), torque larger hex nut (relief body) to 20-25 ft.lbs.*

REPLACING HANDLE PARTS

If replacing damaged handle parts, clean threads with loctite primer and install using loctite 242. Torque parts as shown in Figure 4.

Figure 4
Prince LVR
Valve

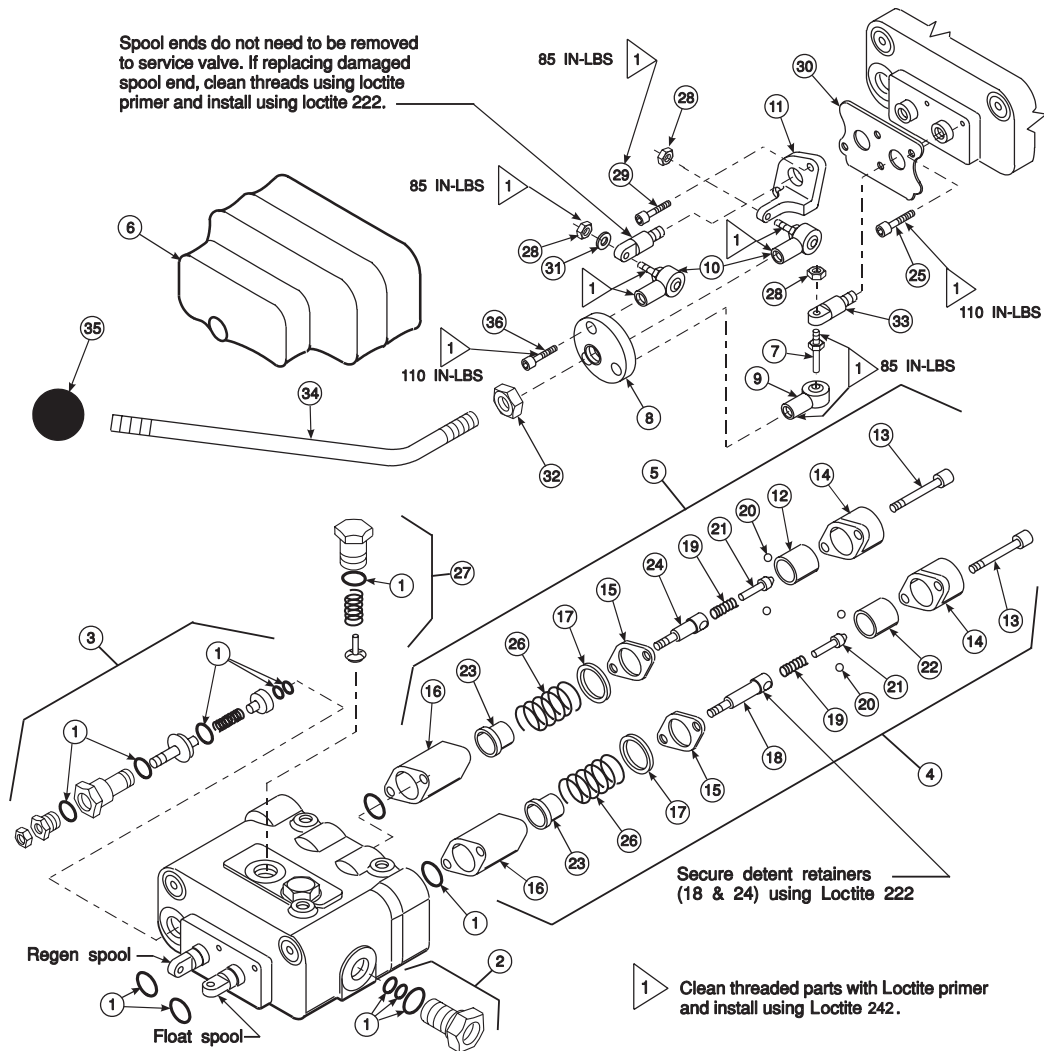

PARTS LIST - PRINCE LVR VALVE

Item	Part No.	Description	Qty.
1	43633	SEAL KIT	1
2	43636	POWER BEYOND SLEEVE	1
3	43637-4	RELIEF VALVE	1
4	43638	FLOAT KIT (Includes items 13, 14, 15, 16, 17, 18, 19, 20, 21, 22, 23 and 26)	1
5	43639	REGEN KIT (Includes items 12, 13, 14, 15, 16, 17, 19, 20, 21, 24 and 26)	1
6	43635	BOOT	1
7	51076	STUD, Spool	1
8	51078	ADAPTER PLATE	1
9	38900-4	ROD END	1
10	51075	ROD END, Assembly	2
11	51079	CLEVIS	1
14	44476-3	END CAP(Manufacturers part number stamped on end cap identifies valve and relief setting)	2
25	44743-5	SCREW, Cap, Socket Head, 1/4-20 x 1/2	2
26	44460	PLUG, Load Check	2
28	G120368	NUT, Hex, 5/16-18	3
29	44743-3	SCREW, Cap, Socket Head, 1/4-20 x 7/8	2
30	51080	PLATE	1
31	51081	WASHER, Shim, 5/16	1
32	G271506	NUT, Hex, 7/16-20	1
33	51077	END, Spool	2
34	43517	HANDLE, Standard	1
35	38902	BALL, Handle	1
36	44743-4	SCREW, Cap, Socket Head, 5/16-24 x 3/4"	3

NOTE: Items not listed individually are not available as separate items.