

**SMC 2410  
LOADER MOUNTING KIT INSTRUCTIONS  
JOHN DEERE 5200, 5300 AND 5400 TRACTORS**

Mounting brackets can be installed using tools ordinarily available. Shut off tractor engine and engage tractor brakes during installation.

**NOTE:** Leave all attaching hardware loose until mounting brackets are completely assembled to facilitate assembly and proper alignment. Tighten all hardware to torque specifications in loader operators manual.

**INSTALLING MOUNTING BRACKETS (Figure 1)**

1. Fasten front mounting bracket (1), with longer flange on top, to tractor front casting using 3/4 x 1-3/4 cap screws (13) and 3/4 lock washers (15) in the front

holes and 5/8 x 1-1/2 cap screws (14) and 5/8 lock washers (11) in side holes.

2. Fasten right and left mid mounting brackets (3 & 4) to tractor transmission casting using 20MM x 40MM cap screws (10), 20MM lock washers (17) in rear holes and 16MM x 50MM cap screws (5) and 5/8 lock washers (11) in front holes.

3. Fasten crossplate (2) to right and left mid mounting brackets (3&4) using 3/4 x 2 cap screws (8) and 3/4 lock nuts (9).

**PARTS LIST - MOUNTING KIT**

ITEM	PART NO.	DESCRIPTION	QTY.
1	41678	BRACKET, Front Mounting	1
2	41686	CROSSPLATE	1
3	41690	BRACKET, Midmounting, Right	1
4	41684	BRACKET, Midmounting, Left (not shown)	1
5	6090-14	SCREW, Cap, Metric, 16MM-2.0MM x 40MM	1
6	G131016	WASHER, Flat, 5/8 SAE	4
7	41680	YOKE Assembly	4
8	G271771	SCREW, Cap, 3/4-10 x 2	4
9	G9414076	NUT, Lock 3/4-10	4
10	6090-67	SCREW, Cap, Metric, 20MM-2.50MM x 40MM	10
11	G121574	WASHER, Lock, 5/8	8
12	G271773	SCREW, Cap, 3/4-10 x 2-1/2	8
13	G271769	SCREW, Cap, 3/4-10 x 1-3/4	6
14	G271547	SCREW, Cap, 5/8-11 x 1-1/2	4
15	G131046	WASHER, Lock, 3/4	4
16	39240	DECAL, Warning "No Tow"	4
17	G11500166	WASHER, Lock, 20MM	2
			8

# INSTALLATION INSTRUCTIONS

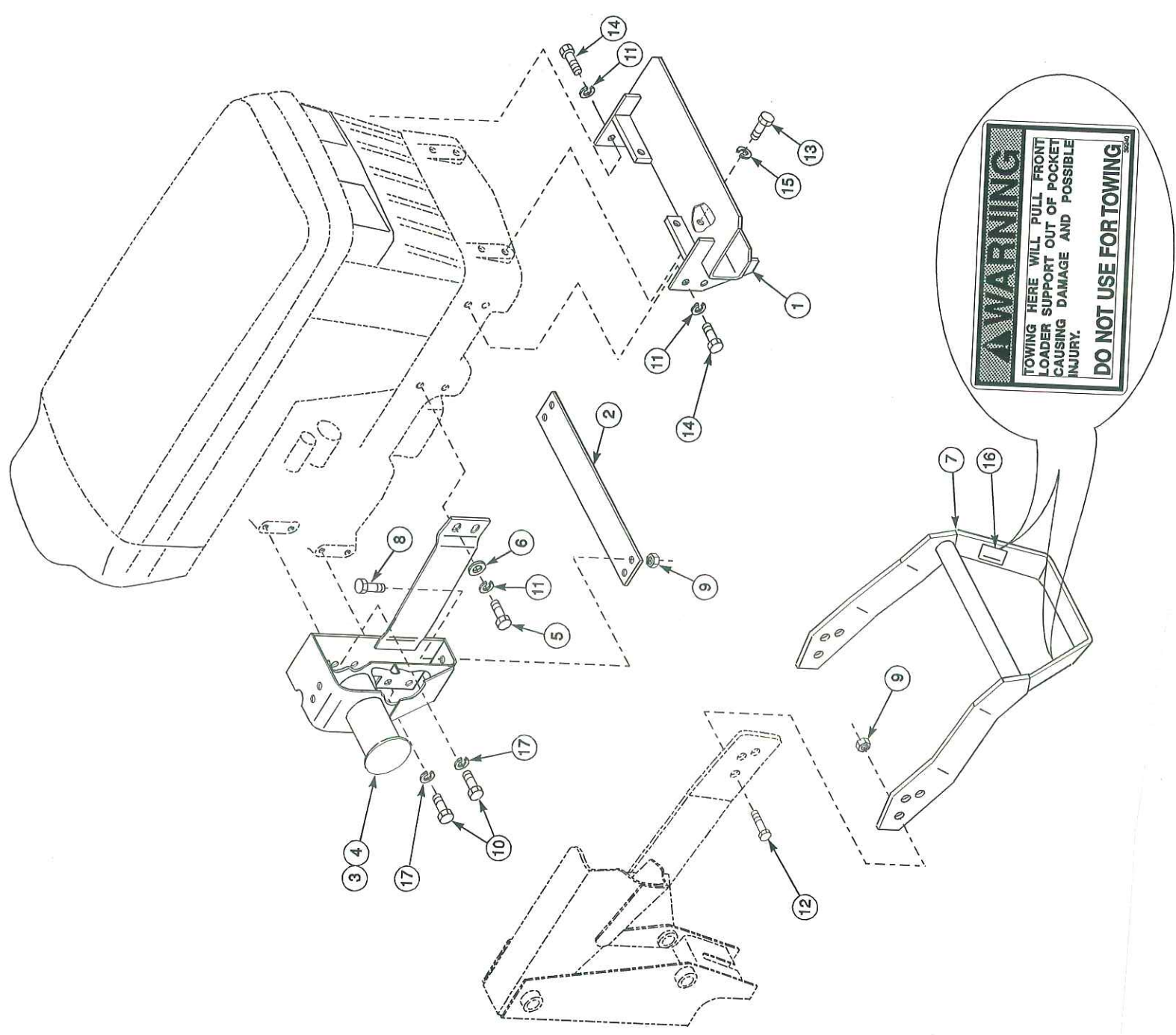



Figure 1  
Mount Kit Assembly

## INSTALLING LOADER TO MOUNTING BRACKETS

## BUNDLE 2-6090

 **WARNING:** To avoid injury during installation of quick attach loader, do not permit bystanders within ten feet of loader.

1. Loop chain under each lift cylinder and hook on loader boom arm. Using overhead hoist to support loader remove hardware securing loader to pallet. Lift loader and remove pallet.

**CAUTION:** Do not damage grease fitting on end of cylinder. Be sure chain does not pinch lift cylinder hose.

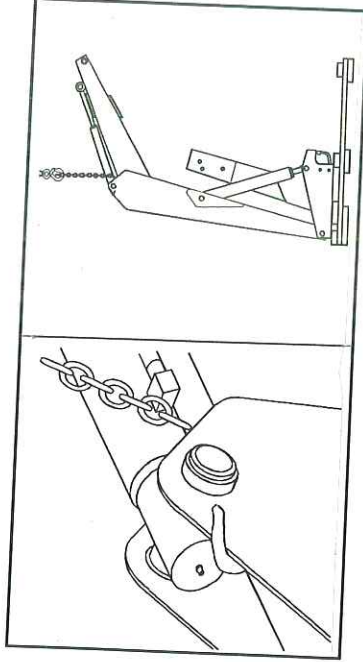

2. Using overhead hoist, lower loader from vertical shipping position to horizontal operating position leaving enough room to install yoke (scraps of cardboard may be used to protect paint). Install yoke assembly (7) using 3/4 x 2-1/2 cap screws (12) and 3/4 lock nuts (9).

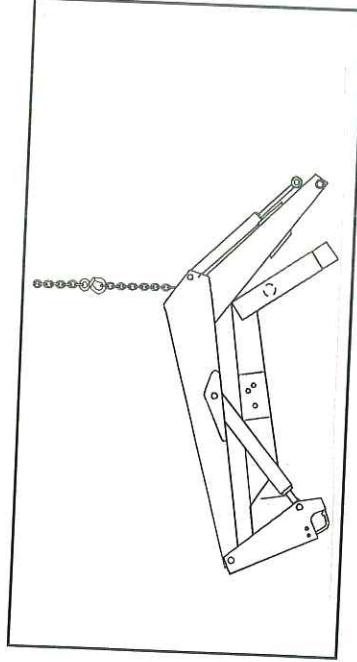

**NOTE:** Hardware connecting yoke to loader sideframes should be snug but do not torque completely. After loader has been mounted to tractor and aligned with midmounting brackets and front mounting operators manual.

3. Install hose or valve kit to loader and tractor. Refer to assembly manual provided for installation instructions.

4. Position tractor close enough so plumbing can be connected to loader. Route hoses loosely to allow maximum reach. Using nylon straps reposition overhead hoist to loader boom arms near pivot point to side frames.

5. Operate loader control valve to extend lift cylinders until front yoke is resting on ground and side frame uprights will clear front tires. Shut off tractor engine and engage tractor brakes. Reroute loader hoses to inside of right midmount bracket. Remove locknut and washer from loader hinge and swing each hinge open.

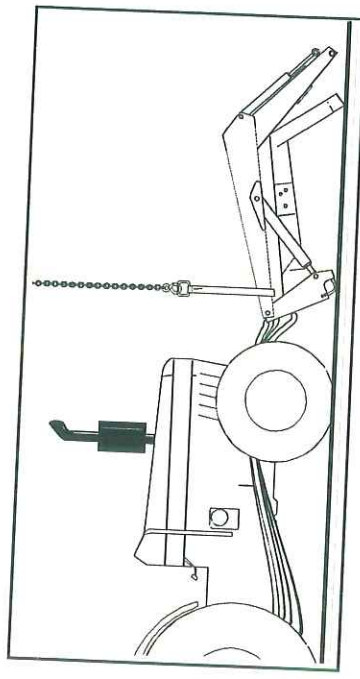

6. Start tractor engine, release tractor brakes and slowly drive forward while operating lift control levers to retract lift cylinders. Position loader so hinges hook over mid mounting tubes. Use of overhead hoist will facilitate positioning loader into mid mounting tubes.

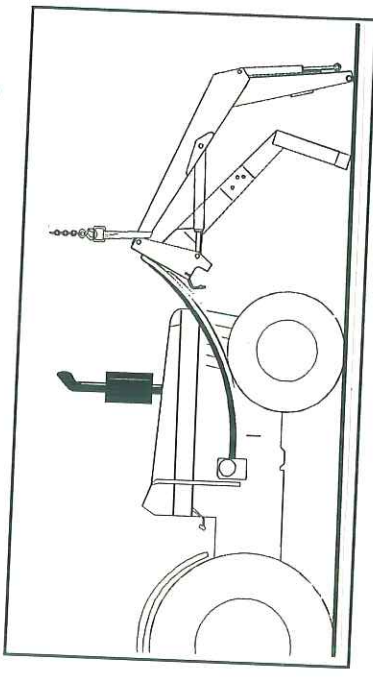

## BUNDLE 2-6090

### INSTALLING LOADER TO MOUNTING BRACKETS (Continued)

**NOTE:** Position loader uprights so mid mounting tubes are tight against hinges until loader has finished rotating so loader front bumper tube does not hit lower flange of front mounting channel.

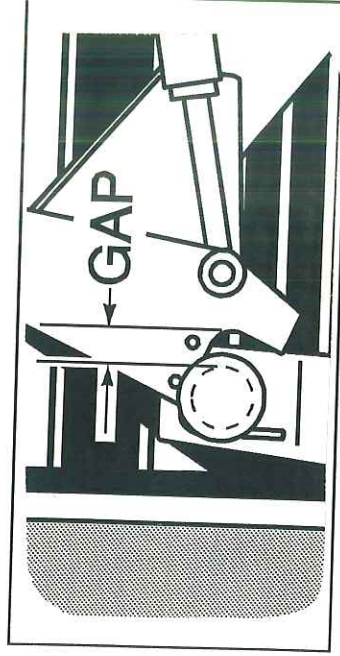

7. With tractor in neutral, retract lift cylinders, bringing side frame up so front yoke tube contacts upper flange of front mounting bracket channel. Move tractor ahead until front yoke tube engages in front mounting channel and upright hinges can clamp around mid mounting tube. Engage tractor brakes and shut off tractor engine.

8. Clamp hinges to midmounting tubes with 3/4 flat washers and 3/4 flex-lock nuts (supplied with loader).

**NOTE:** Only one washer per side is necessary for mounting. Second washer is for shipping purposes only.

**IMPORTANT:** Be sure to use flex-lock nuts to clamp hinge. Tighten flex-lock nuts against hinge securely, but not to more than 125 ft.-lb. torque.

9. Secure hoses using rubber straps to maintain tension on hoses.

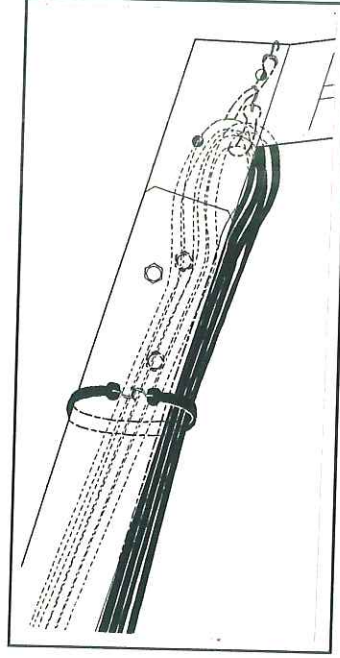

10. Adjust front wheel tread settings or steering stops, if necessary to prevent interference between tires and loader. Refer to tractor operator's manual for adjustment procedures.

### INSTALLING BUCKET OR ATTACHMENT

Refer to loader operator's manual to install bucket or optional attachment.

### INSTALLING BUCKET LEVEL INDICATOR

1. Attach indicator guide tube to cylinder pin. Guide tube is positioned to outside of boom for pin on attachments and inside of boom when quick attach device is used.

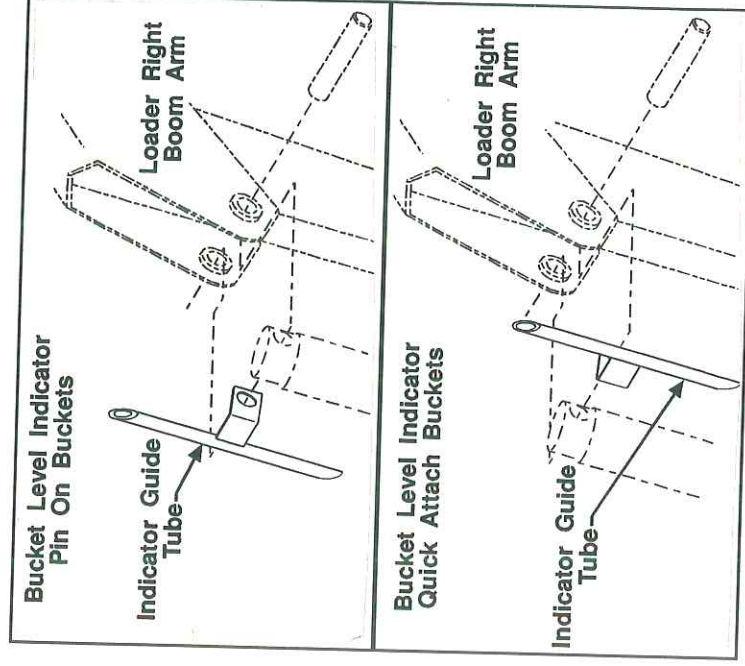

2. Slide bucket level indicator rod through guide tube. Attach other end of rod with 1/8 x 1 cotter pins. If pin on bucket is used, attach lower end of rod to bucket ear. If quick attach device is used, attach lower end of rod to quick attach device.

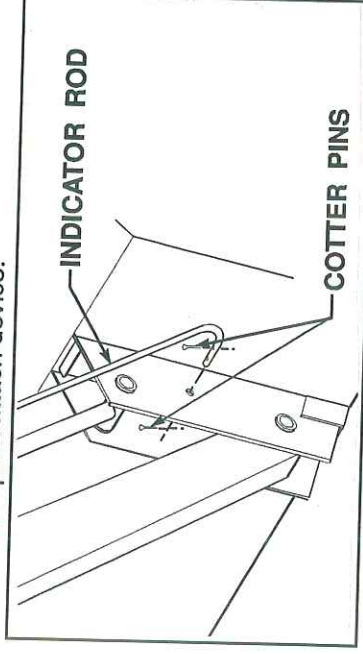

3. Locate tractor and loader on level surface. With bottom of bucket resting on surface, cut off excess rod flush with end of guide tube or paint exposed rod a contrasting color.