

BUNDLE 2-5896
84Q AND 2408 LOADER MOUNTING KIT
NEW HOLLAND 1920 2WD & FWA TRACTORS
WITH OR LESS ARPS 90 OR NEW HOLLAND 758B BACKHOE
AND NEW HOLLAND AUXILIARY VALVE KIT

Mounting brackets can be installed using tools ordinarily available. Shut off engine and engage brakes during installation.

NOTE: *Leave all attaching hardware loose until loader is completely assembled to facilitate assembly and proper alignment. Tighten all hardware to torque specifications in loader operators manual.*

INSTALLING MOUNTING BRACKETS

1. Fasten front mounting bracket (1) to each side of tractor front frame using 1/2 x 1-3/4 cap screws (5) and lock nuts (6).
2. Placing spacers (4) between tractor transmission casting and left mid mounting bracket (2) with chamfered corner of upper spacer to the upper rear, fasten left mid mounting bracket (2) and spacers (4) in place with M16 x 50 metric cap screws (7) and lock washers (8).
3. Fasten right mid mounting bracket (3) to right side of tractor (with chamfered corner to upper rear) using M16 x 50 metric cap screws (7) and lock washers (8).

NOTE: *If tractor is equipped with a mounted remote valve, remove and discard hardware fastening valve mounting bracket to tractor Sandwich valve mounting bracket between right mid mounting bracket (3) and tractor transmission casting.*

INSTALLING LOADER TO MOUNTING BRACKETS

1. Attach nylon slings around the loader front bumper and use an overhead hoist to support loader while removing pallet attachment brackets from loader. Remove 3/8 lock nuts and shoulder bolts which secure flat brackets to loader and remove 3/4 lock nuts and carriage bolts which secure angle brackets to loader, then remove pallet. Reinstall hardware to loader to secure pins and hinges to loader.
2. Remove 5/8 x 2-1/4 cap screws, washers and lock nuts so hinges can be opened. Lower loader to a horizontal position and attach nylon slings around the loader lift boom arms.
3. Use overhead hoist to raise the loader and position the side frame channels over the front mounting bracket. Slide loader to rear until side frame uprights are on the mid mounting tubes.

NOTE: *Lower lip of side frame channel must be between front mounting tubes.*

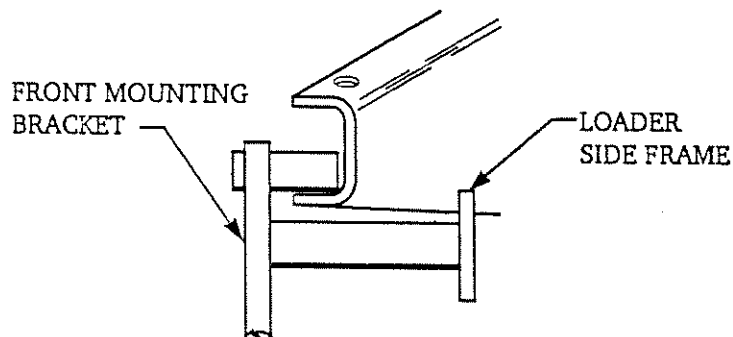

4. Clamp hinges around tubes of mid mounting crosstie. Fasten with 5/8 x 2-1/4 cap screws, flat washers lock washers and nuts (supplied with loader).
5. Refer to the loader owners manual and plumbing kit instructions to complete the loader installation and for location of decals.

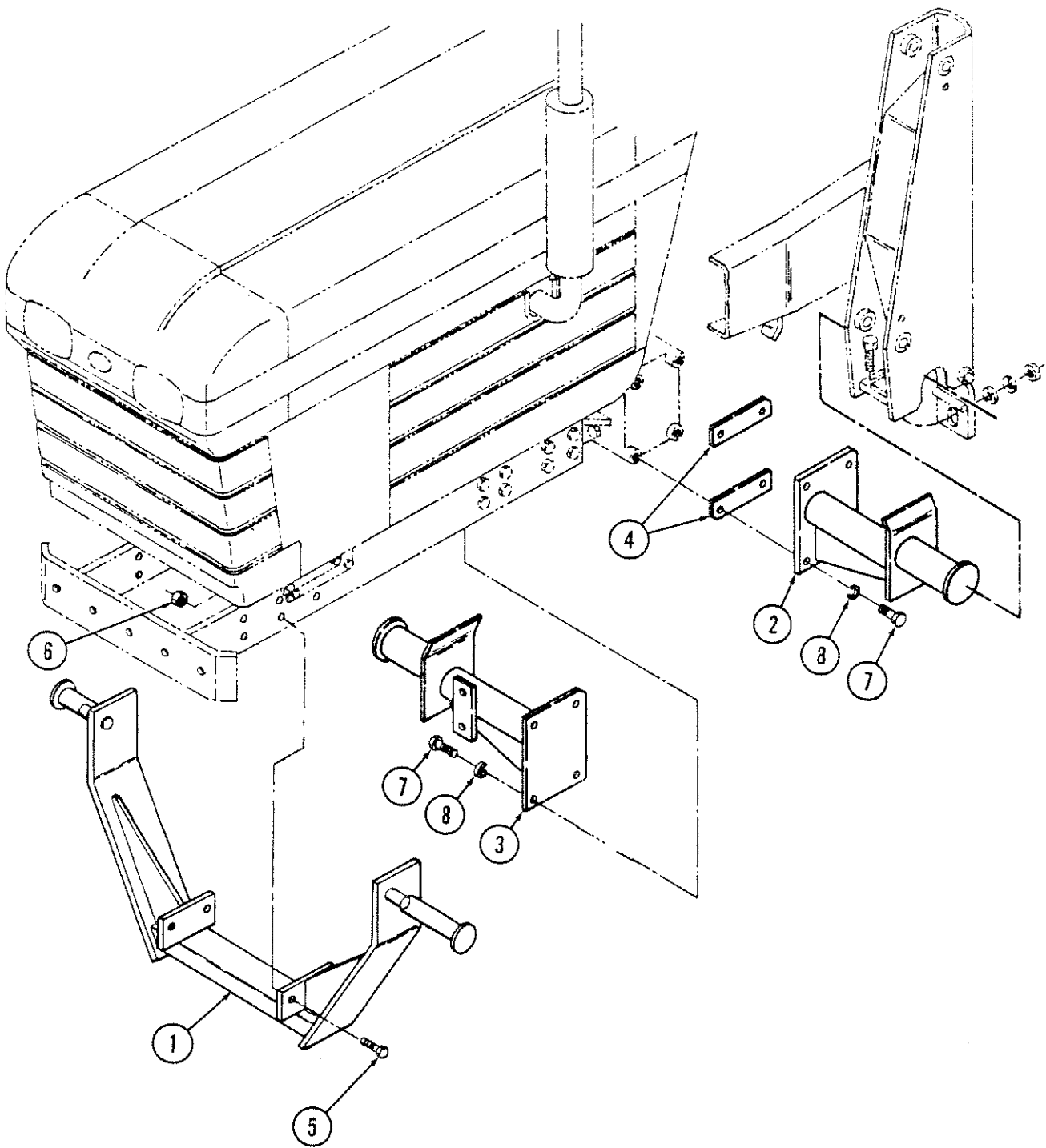

PARTS LIST

Item	Part No.	Description	Qty.
1	39976	BRACKET, Front Mounting	1
2	38201	BRACKET, Mid Mounting, Left	1
3	38202	BRACKET, Mid Mount, Right	1
4	38049	SPACER, Flat	1
5	G180179	SCREW, Cap, 1/2-13 x 1-3/4	2
6	G9414074	NUT, Lock, 1/2-13	4
7	6090-14	SCREW, Metric Cap, 16-2.00 x 50	4
8	G121574	WASHER, Lock, 5/8	8