

BUNDLE 2-5650
64QS LOADER SINGLE HANDLE CONTROL VALVE AND PLUMBING
TO TRACTOR HYDRAULICS INSTRUCTIONS FOR
JOHN DEERE 750 2WD & 4WD TRACTORS

The valve and plumbing can be installed on the tractor and loader using tools ordinarily available. Engage the tractor brakes and shut off tractor engine during installation.

NOTE: Apply sealant only to all tapered threads except when coupled with swivel adapters. When using teflon tape, wrap tape clockwise (as viewed from end) and wrap tape only twice. Keep sealant away from first two threads of tapered end to prevent contamination of hydraulic fluid. Do not use sealant on SAE or JIC threads.

ATTACHING ENCLOSED VALVE AND STAND TO LOADER MOUNTING BRACKET

1. Fasten valve stand tube (35) to tab on right branch of loader mid mounting tube using 1/2 x 2-1/2 cap screws (36), flat washers (37) and lock nuts (38).
2. Remove cover (26) of valve enclosure by removing #10 x 1/2 pan head screws (28). Reposition elbow fitting in power beyond port of valve as necessary and fasten valve box (25) to valve stand tube through pair of holes near corner of valve box using 3/8 x 2-1/4 cap screws (39) and lock nuts (40).

NOTE: To avoid chafing the power beyond hose, keep the bend radius as large as possible by routing it between the front plate of enclosure and tube attachment tab.

3. Retighten jam nut on power beyond elbow (15) and refasten cover (26) to valve box (25) using original #10 x 1/2 pan head screws (28). Making sure the surface of valve box is clean and dry, remove backing from decal (41) and apply it to box where it will be visible to the operator.

PLUMBING CONTROL VALVE TO TRACTOR HYDRAULICS

1. Remove plugs from both ports of tractor hydraulic outlet and from tank port located on right side of tractor transmission casing. Install 1/4-18 hex socket pipe plug (42) inside lower (pressure) port of hydraulic outlet to block internal flow within the hydraulic outlet. Install 9/16 - 3/4 straight fittings (43) into both ports of hydraulic outlet. Install 9/16 - 9/16 x 90° elbow fittings (44) onto straight fittings (43). Install 3/4 - 9/16 x 90° elbow fitting (45) into tractor tank port.
2. Route hoses (20, 21 & 22) down along valve mounting tube (35), under tractor footrest platform and up behind tractor fender to hydraulic outlet. Connect 3/8 x 72 pressure hose (20—from valve port marked “IN”) to 9/16 - 9/16 x 90° elbow fitting (44) in lower port. Connect 3/8 x 60 power beyond hose (22—from valve port marked “PB”) to fitting (44) in upper port. Route 3/8 x 78 tank hose (21—from valve port marked “OUT”) across transmission casing to fitting (45) in tank port.
3. Secure hoses (20, 21 & 22) to underside of tractor footrest platform with one tie strap (46) and to valve stand tube (35) with other tie strap (46).

PLUMBING LOADER TO CONTROL VALVE

1. Install 1/4 x 60 hoses (47) onto boom oil line tubes. Install and tighten hose fittings one at a time from the bottom up. Loosening the closest oil line clamp will ease hose installation.
2. Install 5/8 spiral bands (48) onto free ends of hoses (47) to match bands on female quick couplers (30). Slide nylon sleeve (49) over hoses (47) and install male quick couplers (50) onto ends of hoses.

PLUMBING LOADER TO CONTROL VALVE (continued)

3. Connect hoses from the upper two boom oil lines to the lower quick couplers and connect hoses from the lower boom oil lines to the upper two quick couplers. Wrap one end of rubber strap (51) around hoses and sleeve and hook it onto itself. Hook the other end to bolt through loader bumper and front corner of right side frame channel.
4. After all plumbing has been completed and all parts are secure, start the tractor engine and slowly cycle the lift and bucket cylinders several times to purge any air out of the system, then retract the cylinders and shut off the tractor engine. Add additional tractor hydraulic fluid as specified in the tractor owner's manual to bring the level of hydraulic fluid up to full.

NOTE: When cycling the loader, operate the loader according to the operation decal (41) on valve box. If direction of control lever is wrong, or loader will not lower, recheck connections shown.



WARNING: Escaping hydraulic fluid under pressure can have sufficient force to penetrate the skin causing serious personal injury. If injured by escaping hydraulic fluid, obtain medical treatment immediately.

PARTS LIST

Item	Part No.	Description	Qty.
*1	38411	Valve, DFP Model 1627 FT	1
*2	38903	Angle, Handle Attachment	1
*3	38911-1	SCREW, Flat Head Socket, 5/16-24 x 3/4	1
*4	38910-2	SCREW, Socket Head Cap, 5/16-24 x 3/4	1
*5	38908	LEVER, Valve Handle	1
*6	38901-5	BALL JOINT, Male	2
*7	38900-5	BALL JOINT, Female	1
*8	38904-1	STUD, Ball Joint	1
*9	38910-1	SCREW, Socket Head, 1/4-28 x 3/4	3
*10	G120392	WASHER, Flat, 1/4	3
*11	G120380	WASHER, Lock, 1/4	2
*12	G120367	NUT, Hex, 1/4-28	2
*13	G9416430	NUT, Lock, 1/4 x 28	2
*14	36584	FITTING, Power Beyond Sleeve	1
*15	32845-1	FITTING, Elbow, 9/16 SAE - 9/16 JIC x 90°	1
*16	38928-1	HOSE, 3/8 x 6-15/16	1
*17	38928-2	HOSE, 3/8 x 7-7/8	1
*18	38928-3	HOSE, 3/8 x 8-1/2	1
*19	38928-4	HOSE, 3/8 X 13	1
*20	36388-3	HOSE, 3/8 x 72	1
*21	36388-7	HOSE, 3/8 x 78	1
*22	36386-4	HOSE, 3/8 x 60	1
*23	G180044	SCREW, Cap, 1/2-20 x 2	2
*24	G9424215	NUT, Lock, 1/4 x 20	2
*25	38926	BOX, Valve Mounting	1
*26	38927	COVER, Valve Box	1
*27	38440-1	NUT, Panel, "J" Clip	2
*28	G9426105	SCREW, Pan Head Type AB, #10-16 x 1/2	2
*29	38912	SPACER, Quick Coupler	4
*30	6147-4	COUPLER, Female Quick	4

*Items 1 through 34 have been preassembled.

PARTS LIST (continued)

Item	Part No.	Description	Qty.
*31	36240-9	BAND, Spiral, 1, Blue	1
*	36240-10	BAND, Spiral, 1, Red	1
*	36240-11	BAND, Spiral, 1, Yellow	1
*	36240-12	BAND, Spiral, 1, Green	1
*32	38653	BOOT, Handle	1
*33	38930-1	CAP NUT	1
*34	38902	KNOB, Valve Handle	1
35	39116	TUBE, Valve Mounting Stand	1
36	G180185	SCREW, Cap, 1/2-13 x 2-1/2	2
37	G120396	WASHER, Flat, 1/2	2
38	G9414074	NUT, Lock, 1/2-13	2
39	G180132	SCREW, Cap, 3/8-16 x 2-1/4	2
40	G9413534	NUT, Lock, 3/8-16	2
41	38929	DECAL, Single Lever Control	1
42	G444691	FITTING, Plug, Hex Socket, 1/4-18	1
43	32844-5	FITTING, Straight, 3/4 SAE - 9/16 JIC	2
44	34128-3	FITTING, Elbow, 9/16 SAE - 9/16 JIC x 90°	2
45	32845-7	FITTING, Elbow, 3/4 SAE - 9/16 JIC x 90°	1
46	8137-1	STRAP, Plastic, 3/16 x 11	2
47	36251-3	HOSE, 1/4 x 60	4
48	36240-5	BAND, Spiral, 5/8, Blue	1
	36240-6	BAND, Spiral, 5/8, Red	1
	36240-7	BAND, Spiral, 5/8, Yellow	1
	36240-8	BAND, Spiral, 5/8, Green	1
49	34853-11	SLEEVE, Nylon Hose	1
50	6137-4	COUPLER, Male Quick	4
51	7438-1	STRAP, Rubber	1

*Items 1 through 34 have been preassembled.

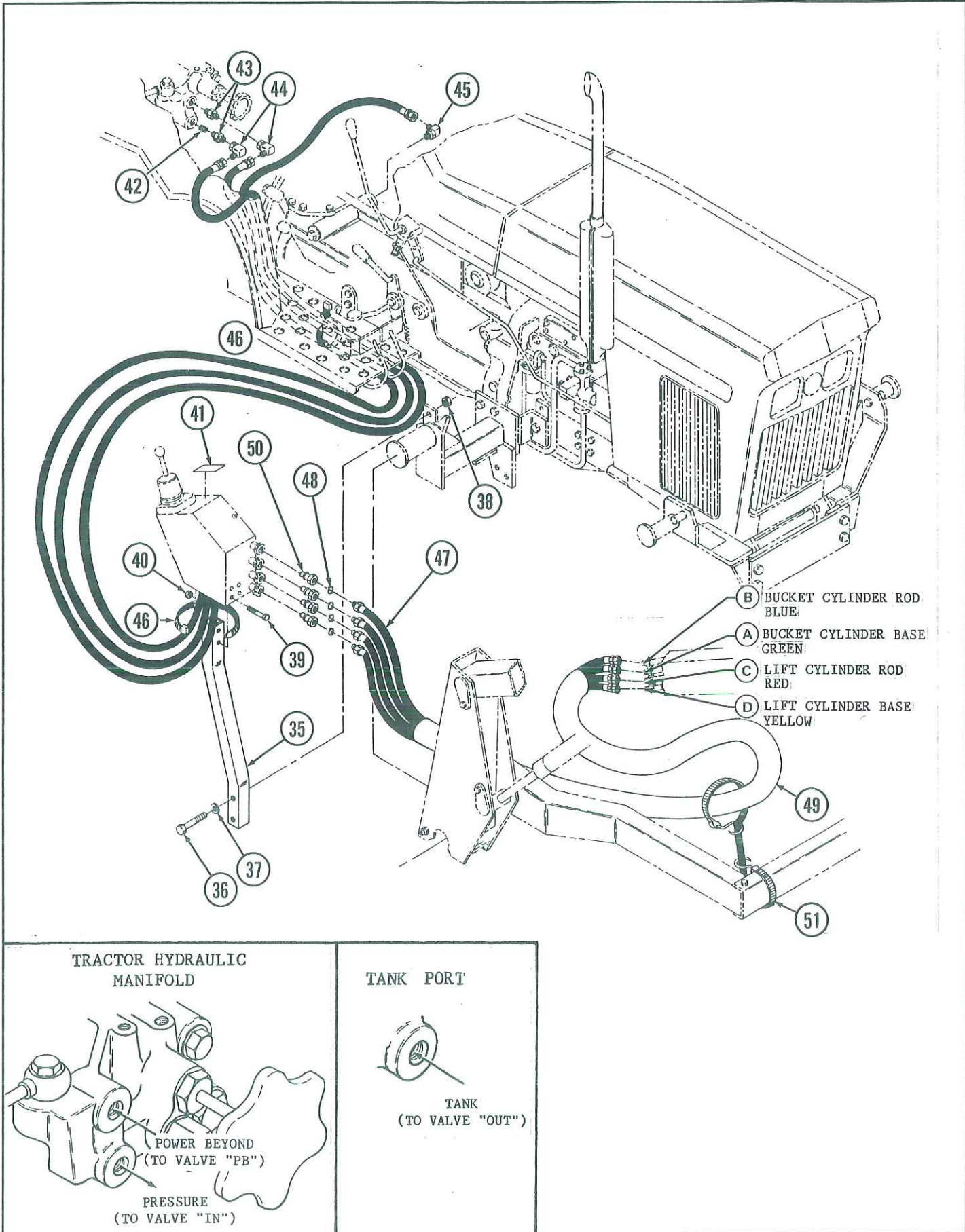

- B BUCKET CYLINDER ROD
BLUE
- A BUCKET CYLINDER BASE
GREEN
- C LIFT CYLINDER ROD
RED
- D LIFT CYLINDER BASE
YELLOW

**TRACTOR HYDRAULIC
MANIFOLD**

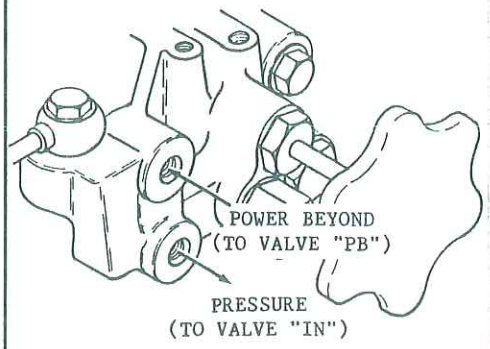

TANK PORT



Figure 1
Control Valve

Figure 1A

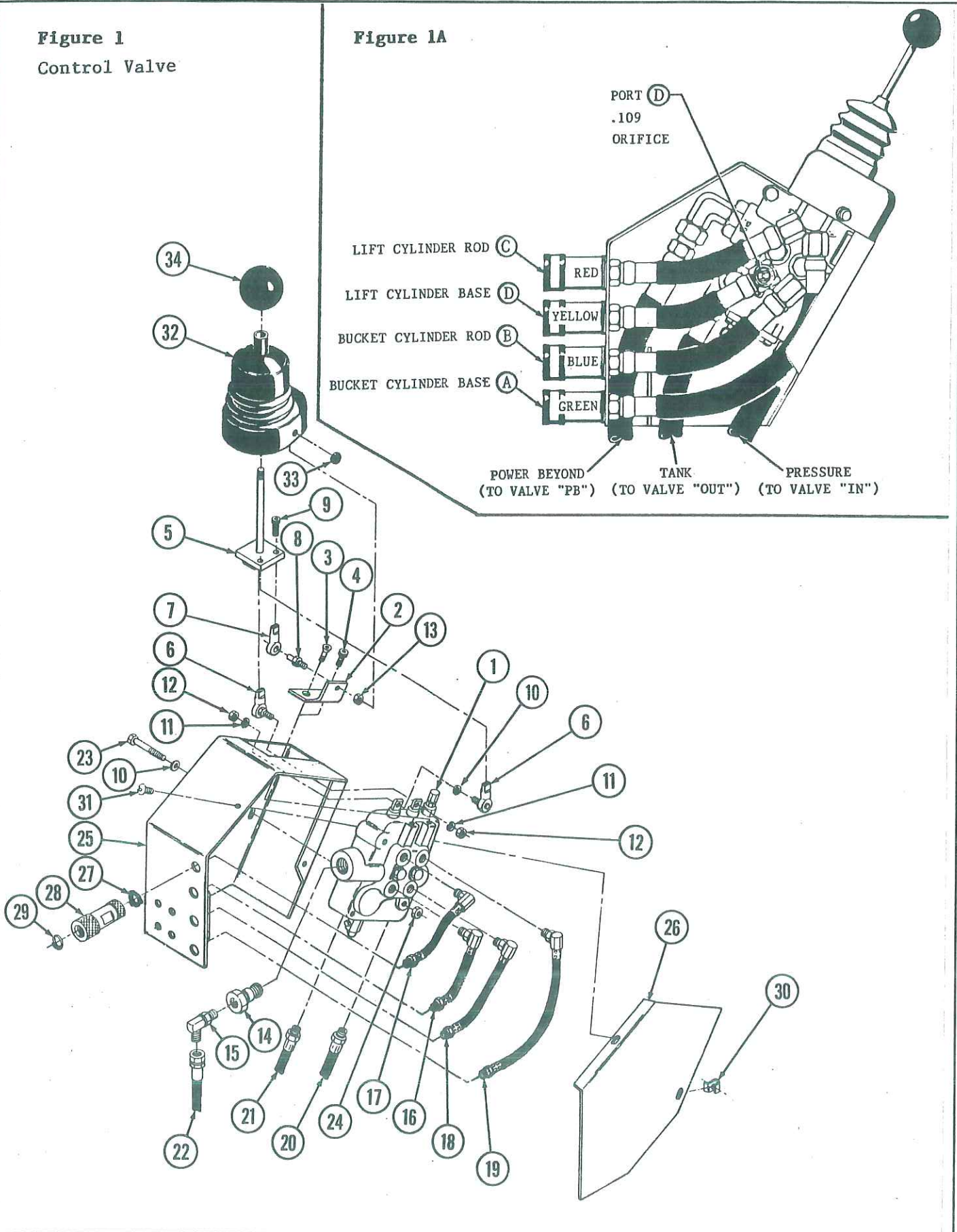

ENCLOSED VALVE AND HANDLE DISASSEMBLY AND REASSEMBLY

If it is necessary to replace or repair any component of the valve enclosure or handle, it will need to be disassembled to the point where the damaged part is removed, then reassembled with a new part. If a part should fail during the warranty period, Return the entire assembly, without disassembling, to your authorized service department or contact your service department for instructions. See the 64QS & 64Q loader owner's manual for valve service instructions. Unauthorized disassembly of the valve in the warranty period will **VOID WARRANTY**.

Follow the following procedure to disassemble and reassemble the valve handle and enclosure.

NOTE: It is advisable to mark or tag all hoses and parts before disassembly, so parts can be easily identified for reassembly.

VALVE HANDLE DISASSEMBLY

1. Remove the cap nut (33) from threaded end of ball joint stud (8) and unscrew handle knob (34) from end of valve handle (5). Slip rubber boot (32) off ball joint stud (8) and slide rubber boot off valve handle (5).
2. Unscrew 1/4 x 3/4 socket head cap screws (9) from ball joints (6 & 7) to remove valve handle lever (5).

NOTE: The valve, with hoses and fittings, may be removed from the enclosure without further disassembly of the handle mechanism. See **VALVE ENCLOSURE, HOSE AND FITTING DISASSEMBLY** instructions if further disassembly of handle mechanism is not required.

3. Remove 1/4-28 hex nuts (12), lock washers (11) and flat washers (10) which fasten male ball joints (6) onto spools of valve (1).

NOTE: Rotate tilt spool (spool without float) approximately 45° to ease removal of nut (12) and lock washer (11) from male ball joint (6).

4. Slide female ball joint (7) off stud (8) and remove ball joint stud (8) from handle attachment angle (2) by removing 1/4-28 lock nut (13).
5. Remove handle attachment angle (2) from valve (1) by removing 5/16 x 3/4 flat head cap screw (3) and socket head cap screw (4).

VALVE ENCLOSURE, HOSE AND FITTING DISASSEMBLY

1. Remove handle attachment angle (2) from valve (1) by removing 5/16 x 3/4 flat head cap screw (3) and socket head cap screw (4).
2. Remove female quick couplers (30), spiral bands (31) and spacers (29) from ends of hoses (16, 17, 18 & 19). Remove hoses (16, 17, 18 & 19) from working ports of valve (1).

NOTE: Do not lose one-way restrictor plate from working port D of valve (1).

VALVE ENCLOSURE, HOSE AND FITTING DISASSEMBLY (continued)

3. Remove 1/4 x 2 cap screws (23) and lock nuts (24) to remove valve with attached fittings and hoses from box (25).
4. Remove hoses (20 & 21) from the inlet and outlet ports of valve (1). Remove 3/8 x 60 hose (22) from fitting (25) in power beyond port of valve (1). Remove elbow fitting (15)

from power beyond sleeve (14).

REASSEMBLING SINGLE LEVER CONTROL ONTO VALVE

1. Fasten handle attachment angle (2) to valve (1) using the 5/16 x 3/4 flat head cap screw (3) and socket head cap screw (4).
2. Fasten ball joint stud (8) to handle attachment angle (2) with 1/4-28 lock nut (13), then slide female ball joint (7) onto stud (8). Fasten both male ball joints (6) onto both spools of valve (1) with 1/4-28 hex nuts (12) and lock washers (11). One quarter-inch washer (10) may be used between the valve lift spool (spool with float) and ball joint (6) to change angle of handle lever (5).

NOTE: Do not lose one-way restrictor plate from working port D of valve (1).

3. Fasten valve handle lever (5) to ball joints (6 & 7) using 1/4-28 x 3/4 socket head cap screws (9).

REASSEMBLING VALVE AND HOSES IN BOX

1. Install 9/16 - 9/16 x 90° elbow (15) into power beyond sleeve (14) in valve port marked "PB".
2. Install 3/8 x 6-15/16 hose (16) into port D of valve (1). Install 3/8 x 7/8 hose (17) into port C, install 3/8 x 8-1/2 hose (18) into port B and install 3/8 x 13 hose (19) into port A. Connect male end of 3/8 x 72 hose (20) into valve port marked "IN," install 3/8 x 78 hose (21) into "OUT" port and install 3/8 x 60 hose (22) onto elbow (15) in power beyond port.

NOTE: Make sure one-way restrictor plate with .109 hole is positioned in working port D with grooved side facing out before installing 3/8 x 6-15/16 hose (16). This plate is to prevent the loader from lowering too fast.

3. Fasten valve with attached hoses and fittings to valve box (25) using 1/4 x 2 cap screws (23) and lock nuts (24). Put ends of working port hoses (16, 17, 18 & 19) through holes in valve box as shown and install female quick couplers (30) and spacers (29). Install colored bands (31) over spacers to identify quick couplers.
4. Slide panel nuts (27) onto valve box (25) and cover (26) and fasten cover (26) onto box using #10 x 1/2 pan head screws (28). Slide rubber boot (32) over valve handle (5) and press around bottom so threaded end of ball joint stud (8) protrudes through hole. Fasten cap nut (33) onto protruding threads. Screw valve handle knob (34) onto end of valve handle.